

4

3

2

1

REVISIONS				
ZONE	LTR.	DESCRIPTION	DATE	APPROVED

APPROVED
By Eric Zuercher at 5:20 pm, Feb 03, 2023

NOTES UNLESS OTHERWISE SPECIFIED:

- NOMENCLATURE: VALVE, BREATHER, TWO WAY RELIEF, WITH WEATHERSHIELD.
- PERFORMANCE: SEE TABLES ON SHEET 2 AND 3.
- MATERIALS:
 - WEATHERSHIELD, HOUSING, WASHER, AND HEX NUT: ALUMINUM ALLOY.
 - SCREW: STAINLESS STEEL.
 - O-RING: MS28775-112.
- FINISH: WEATHERSHIELD, HOUSING, WASHER, AND HEX NUT: ANODIZED IAW MIL-A-8625, TYPE II, CLASS 1. HOUSING ADDITIONALLY CLEAR TEFLON COATED.
- THE FOLLOWING ITEMS FURNISHED AS PART OF THE ASSEMBLY MAY BE PURCHASED SEPARATELY:

P/N	225010-16	HEX NUT
	225011-16	WASHER
	MS28775-112	O-RING
- SUGGESTED INSTALLATION TORQUE IS 25 ±5 IN-LBS.

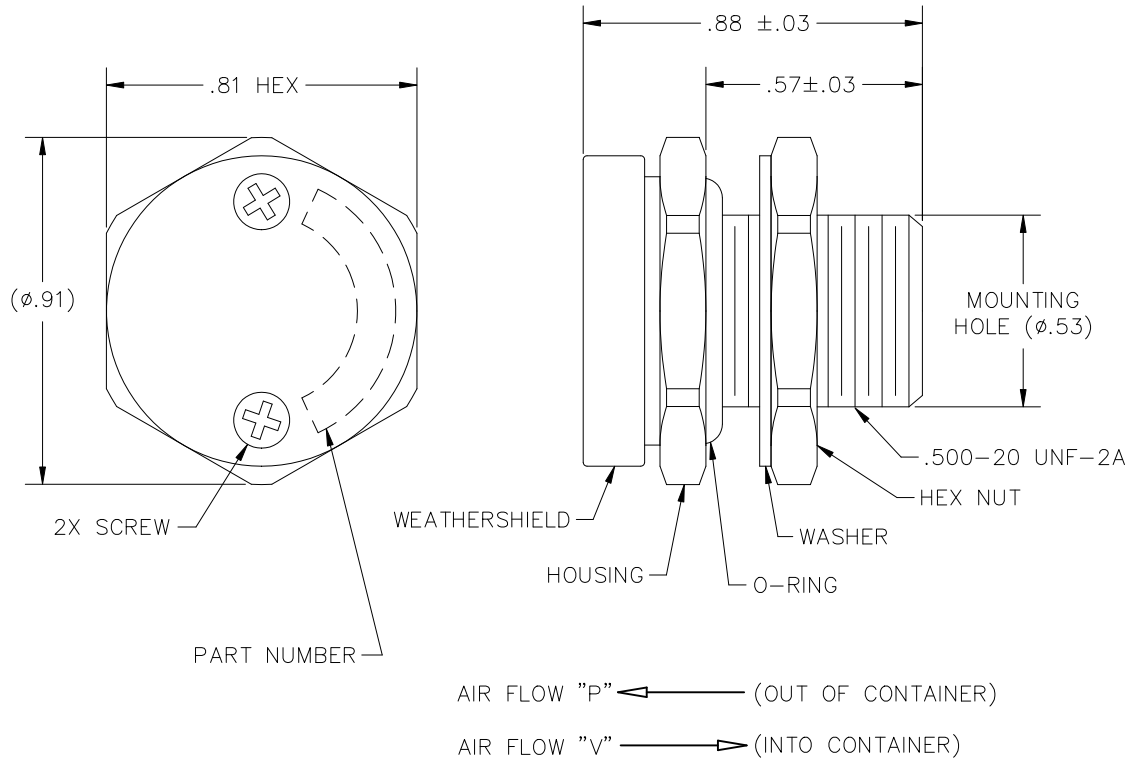

				INTERPRET DIMENSIONS AND TOLERANCES IAW ASME Y14.5M-1994		CONTRACT	
				UNLESS OTHERWISE SPECIFIED DIMENSIONS ARE IN INCHES		DRAWN	
				TOLERANCES:		DATE	
				DECIMALS	ANGLES	CHECK	
				.XX ±.015	±.5°	P.LANE	
				.XXX ±.010		9-26-16	
				DO NOT SCALE DRAWING			
				APPROVED			
				P.LANE			
				9-26-16			
				MANUFACTURING			
				CUSTOMER			
PART DASH NO.	NEXT FINAL	QTY. REQ'D PER ASSY.	NEXT ASSY.	USED ON	SIMILAR TO	ACT. WT.	CALC. WT.
			FINAL		4.		
APPLICATION							
4.							

agm CONTAINER CONTROLS, INC. P.O. BOX 40020 - TUCSON, ARIZONA 85717-0020			
TITLE			
BREATHER VALVE			
SIZE	FSCM NO.	DWG. NO.	REV
C	08992	TA225	A
SCALE 4/1	RELEASE DATE	SHEET	1 OF 3

4

3

2

1

REVISIONS				
ZONE	LTR.	DESCRIPTION	DATE	APPROVED

RESEAL VALVE PERFORMANCE

PART NUMBER	PRESSURE SIDE (FLOW OUT)			VACUUM SIDE (FLOW IN)		
	CRACKING PRESSURE RANGE (PSID)	RESEAL PRESSURE AFTER CRACK, MIN (PSID)	MINIMUM FLOW RATE (SLPM BY PSID)	CRACKING PRESSURE RANGE (PSID)	RESEAL PRESSURE AFTER CRACK, MIN (PSID)	MINIMUM FLOW RATE (SLPM BY PSID)
TA225-05-05	0.50-1.00	0.50	9 BY 2.00	0.50-1.00	0.50	17 BY 2.00
TA225-05-10	0.50-1.00	0.50	9 BY 2.00	1.00-1.50	1.00	28 BY 2.50
TA225-05-15	0.50-1.00	0.50	9 BY 2.00	1.50-2.00	1.50	25 BY 3.00
TA225-05-20	0.50-1.00	0.50	9 BY 2.00	2.00-3.00	2.00	15 BY 3.50
TA225-05-25	0.50-1.00	0.50	9 BY 2.00	2.50-3.50	2.50	30 BY 4.00
TA225-10-10	1.00-1.50	1.00	11 BY 2.50	1.00-1.50	1.00	28 BY 2.50
TA225-10-15	1.00-1.50	1.00	11 BY 2.50	1.50-2.00	1.50	25 BY 3.00
TA225-10-20	1.00-1.50	1.00	11 BY 2.50	2.00-3.00	2.00	15 BY 3.50
TA225-10-25	1.00-1.50	1.00	11 BY 2.50	2.50-3.50	2.50	30 BY 4.00
TA225-10-30	1.00-1.50	1.00	11 BY 2.50	3.00-4.00	3.00	30 BY 4.50
TA225-15-15	1.50-2.00	1.50	18 BY 3.00	1.50-2.00	1.50	25 BY 3.00
TA225-15-20	1.50-2.00	1.50	18 BY 3.00	2.00-3.00	2.00	15 BY 3.50
TA225-15-25	1.50-2.00	1.50	18 BY 3.00	2.50-3.50	2.50	30 BY 4.00
TA225-15-30	1.50-2.00	1.50	18 BY 3.00	3.00-4.00	3.00	30 BY 4.50
TA225-15-35	1.50-2.00	1.50	18 BY 3.00	3.50-4.50	3.50	30 BY 5.00
TA225-20-20	2.00-3.00	2.00	8 BY 3.50	2.00-3.00	2.00	15 BY 3.50
TA225-20-25	2.00-3.00	2.00	8 BY 3.50	2.50-3.50	2.50	30 BY 4.00
TA225-20-30	2.00-3.00	2.00	8 BY 3.50	3.00-4.00	3.00	30 BY 4.50
TA225-20-35	2.00-3.00	2.00	8 BY 3.50	3.50-4.50	3.50	30 BY 5.00
TA225-20-40	2.00-3.00	2.00	8 BY 3.50	4.00-5.00	4.00	30 BY 5.50
TA225-25-25	2.50-3.50	2.50	10 BY 4.00	2.50-3.50	2.50	30 BY 4.00
TA225-25-30	2.50-3.50	2.50	10 BY 4.00	3.00-4.00	3.00	30 BY 4.50
TA225-25-35	2.50-3.50	2.50	10 BY 4.00	3.50-4.50	3.50	30 BY 5.00
TA225-25-40	2.50-3.50	2.50	10 BY 4.00	4.00-5.00	4.00	30 BY 5.50

TABLE CONTINUED ON SHEET 3

SIZE C	FSCM NO. 08992	DWG. NO. TA225	REV A
SCALE NONE	SHEET 2		

4

3

2

1

4

3

2

1

REVISIONS				
ZONE	LTR.	DESCRIPTION	DATE	APPROVED

TABLE CONTINUED FROM SHEET 2

RESEAL VALVE PERFORMANCE						
PART NUMBER	PRESSURE SIDE (FLOW OUT)			VACUUM SIDE (FLOW IN)		
	CRACKING PRESSURE RANGE (PSID)	RESEAL PRESSURE AFTER CRACK, MIN (PSID)	MINIMUM FLOW RATE (SLPM BY PSID)	CRACKING PRESSURE RANGE (PSID)	RESEAL PRESSURE AFTER CRACK, MIN (PSID)	MINIMUM FLOW RATE (SLPM BY PSID)
TA225-25-45	2.50-3.50	2.50	10 BY 4.00	4.50-5.50	4.50	30 BY 6.00
TA225-30-30	3.00-4.00	3.00	6 BY 4.50	3.00-4.00	3.00	30 BY 4.50
TA225-30-35	3.00-4.00	3.00	6 BY 4.50	3.50-4.50	3.50	30 BY 5.00
TA225-30-40	3.00-4.00	3.00	6 BY 4.50	4.00-5.00	4.00	30 BY 5.50
TA225-30-45	3.00-4.00	3.00	6 BY 4.50	4.50-5.50	4.50	30 BY 6.00
TA225-30-50	3.00-4.00	3.00	6 BY 4.50	5.00-6.00	5.00	30 BY 6.50
TA225-35-35	3.50-4.50	3.50	6 BY 5.00	3.50-4.50	3.50	30 BY 5.00
TA225-35-40	3.50-4.50	3.50	6 BY 5.00	4.00-5.00	4.00	30 BY 5.50
TA225-35-45	3.50-4.50	3.50	6 BY 5.00	4.50-5.50	4.50	30 BY 6.00
TA225-35-50	3.50-4.50	3.50	6 BY 5.00	5.00-6.00	5.00	30 BY 6.50
TA225-40-40	4.00-5.00	4.00	6 BY 5.50	4.00-5.00	4.00	30 BY 5.50
TA225-40-45	4.00-5.00	4.00	6 BY 5.50	4.50-5.50	4.50	30 BY 6.00
TA225-40-50	4.00-5.00	4.00	6 BY 5.50	5.00-6.00	5.00	30 BY 6.50
TA225-45-45	4.50-5.50	4.50	6 BY 6.00	4.50-5.50	4.50	30 BY 6.00
TA225-45-50	4.50-5.50	4.50	6 BY 6.00	5.00-6.00	5.00	30 BY 6.50
TA225-50-50	5.00-6.00	5.00	8 BY 6.50	5.00-6.00	5.00	30 BY 6.50

CRACKING VALVE PERFORMANCE						
PART NUMBER	PRESSURE SIDE (FLOW OUT)			VACUUM SIDE (FLOW IN)		
	CRACKING PRESSURE RANGE (PSID)	RESEAL PRESSURE AFTER CRACK, MIN (PSID)	MINIMUM FLOW RATE (SLPM BY PSID)	CRACKING PRESSURE RANGE (PSID)	RESEAL PRESSURE AFTER CRACK, MIN (PSID)	MINIMUM FLOW RATE (SLPM BY PSID)
TA225-025C-025C	0.10-0.40	0.10	13 BY 1.75	0.10-0.40	0.10	20 BY 1.75
TA225-10C-10C	0.75-1.25	0.50	11 BY 2.50	0.75-1.25	0.50	28 BY 2.50

SIZE C	FSCM NO. 08992	DWG. NO. TA225	REV A
SCALE NONE	SHEET 3		

4

3

2

1