

THIS DOCUMENT CONTAINS PROPRIETARY INFORMATION AND EXCEPT WITH WRITTEN PERMISSION BY AGM CONTAINER CONTROLS, INC. SUCH INFORMATION SHALL NOT BE PUBLISHED, DISCLOSED TO OTHERS OR USED FOR ANY PURPOSE AND THE DOCUMENT SHALL NOT BE DUPLICATED IN WHOLE OR IN PART.

REVISIONS				
ZONE	LTR.	DESCRIPTION	DATE	APPROVED

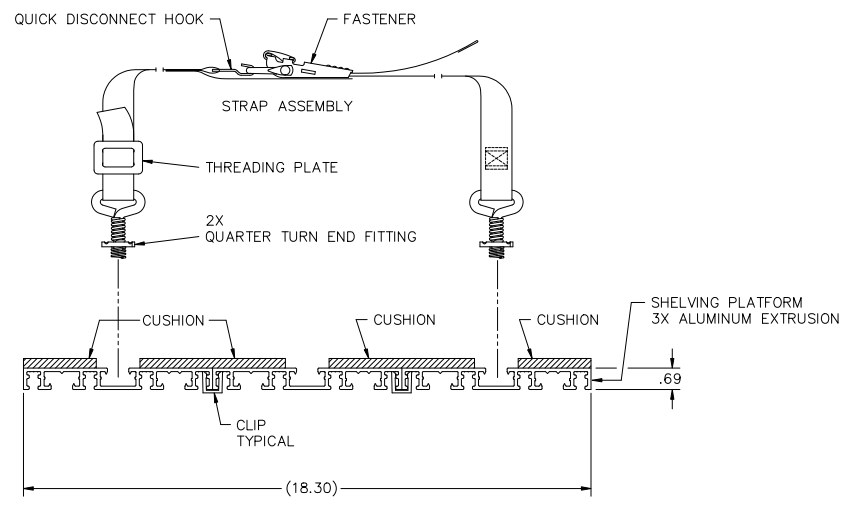

SECTION A-A

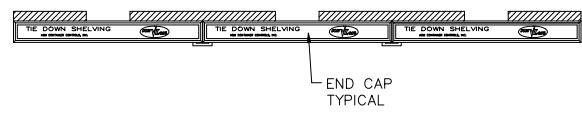

END CAP TYPICAL

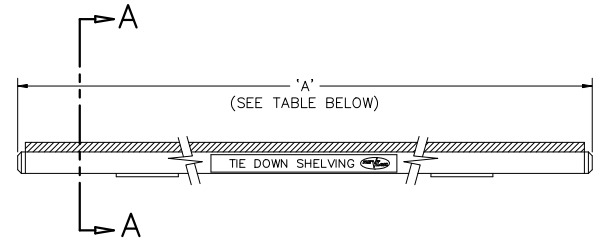

- NOTES:
- DESCRIPTION: SHELVING KIT, SEE PARTS LIST FOR DESCRIPTION AND QUANTITY OF COMPONENTS SUPPLIED WITH EACH KIT. SHELVING KIT IS SUPPLIED PARTIALLY ASSEMBLED AND REQUIRES SOME ASSEMBLY AT POINT OF INSTALLATION. CLIPS ARE PROVIDED FOR TEMPORARY USE DURING SHIPMENT AND ASSEMBLY AND MAY BE REMOVED OR RELOCATED TO FACILITATE ASSEMBLY.
  - MATERIALS:
    - SHELVING PLATFORM: ALUMINUM ALLOY EXTRUSION 6.102 +.030 -.054 WIDE, (3) EACH.
    - CUSHION: COMMERCIAL QUALITY, CLOSED CELL POLYVINYL CHLORIDE FOAM. UNCOMPRESSED THICKNESS APPROXIMATELY .38 INCH. CUSHION BONDED TO SHELVING PLATFORM WITH PERMANENT ACRYLIC PRESSURE SENSITIVE ADHESIVE.
    - CLIP: ALUMINUM ALLOY.
    - END CAP: PLASTIC
    - STRAP ASSEMBLY: SEE DRAWING CT1109.
  - ASSEMBLY PROCEDURE:
    - ATTACH END CAPS TO BOTH ENDS OF SHELVING.
    - ATTACH STRAP ASSEMBLY TO SHELVING BY INSERTING QUARTER TURN END FITTINGS INTO GROOVES ON PADDED SURFACE. ROTATE END FITTINGS ONE-QUARTER TURN CLOCKWISE TO LOCK IN PLACE. STRAP ASSEMBLY MAY BE SEPARATED BY REMOVING QUICK DISCONNECT HOOK FROM WIRE END OF FASTENER. DO NOT UNLACE WEBBING FROM FASTENER. FASTENER MAY BE CENTERED ALONG STRAP BY SLIDING WEBBING THROUGH THREADING PLATE.
    - SHELVING MAY BE SUPPLIED IN LENGTHS OTHER THAN THOSE SHOWN IN TABLE BELOW.

PART NO.	DIM 'A' ±.10	PARTS LIST QUANTITY PER ASSEMBLY	
		STRAP ASSEMBLY	END CAP
KG18-2400	24.00	2	6
KG18-2800	28.00	3	6
KG18-3000	30.00	3	6
KG18-3500	35.00	3	6
KG18-3600	36.00	3	6
KG18-4200	42.00	4	6
KG18-4800	48.00	4	6
KG18-6000	60.00	5	6
KG18-6600	66.00	5	6
KG18-7200	72.00	6	6
KG18-8400	84.00	7	6
KG18-9600	96.00	8	6

SPECIFICATION CONTROL DRAWING

INTERPRET DIMENSIONS AND TOLERANCES IN INCHES UNLESS OTHERWISE SPECIFIED DECIMALS .XXX ±.010 ANGLES ±.5° DO NOT SCALE DRAWING		CONTRACT DATE L.HARTSIG 5-2-96 CHECK P. LANE 2-9-05 APPROVED P. LANE 2-9-05 MANUFACTURING		GGM CONTAINER CONTROLS, INC. P.O. BOX 40020 - TUCSON, ARIZONA 85717-0020	
PART DASH NO. NEXT FINAL QTY. REQD PER ASSY. NEXT ASSY. USED ON APPLICATION		SCALE 1/2 RELEASE DATE		TITLE SHELVING SIZE D 08992 FSCM NO. 08992 DWG. NO. KG18 REV C	