

8 7 6 5 4 3 2 1

THIS DOCUMENT CONTAINS PROPRIETARY INFORMATION AND EXCEPT WITH WRITTEN PERMISSION BY AGM CONTAINER CONTROLS, INC. SUCH INFORMATION SHALL NOT BE PUBLISHED, DISCLOSED TO OTHERS OR USED FOR ANY PURPOSE AND THE DOCUMENT SHALL NOT BE DUPLICATED IN WHOLE OR IN PART.

REVISIONS				
ZONE	LTR.	DESCRIPTION	DATE	APPROVED

NOTES:

- DESCRIPTION: SHELVING KIT, SEE PARTS LIST FOR DESCRIPTION AND QUANTITY OF COMPONENTS SUPPLIED WITH EACH KIT. SHELVING KIT IS SUPPLIED PARTIALLY ASSEMBLED AND REQUIRES SOME ASSEMBLY AT POINT OF INSTALLATION. CLIPS ARE PROVIDED FOR TEMPORARY USE DURING SHIPMENT AND ASSEMBLY AND MAY BE REMOVED OR RELOCATED TO FACILITATE ASSEMBLY.
- MATERIALS:
  - SHELVING PLATFORM: ALUMINUM ALLOY EXTRUSION 6.102 +.030 -.054 WIDE, (3) EACH.
  - CUSHION: COMMERCIAL QUALITY, CLOSED CELL POLYVINYL CHLORIDE FOAM. UNCOMPRESSED THICKNESS APPROXIMATELY .38 INCH. CUSHION BONDED TO SHELVING PLATFORM WITH PERMANENT ACRYLIC PRESSURE SENSITIVE ADHESIVE.
  - CLIP: ALUMINUM ALLOY.
  - STRAP ASSEMBLY: SEE DRAWING CT1109.
- ASSEMBLY PROCEDURE:
  - ATTACH STRAP ASSEMBLY TO SHELVING BY INSERTING QUARTER TURN END FITTINGS INTO GROOVES ON PADDED SURFACE. ROTATE END FITTINGS ONE-QUARTER TURN CLOCKWISE TO LOCK IN PLACE. STRAP ASSEMBLY MAY BE SEPARATED BY REMOVING QUICK DISCONNECT HOOK FROM WIRE END OF FASTENER. DO NOT UNLACE WEBBING FROM FASTENER. FASTENER MAY BE CENTERED ALONG STRAP BY SLIDING WEBBING THROUGH THREADING PLATE.
  - SHELVING MAY BE SUPPLIED IN LENGTHS OTHER THAN THOSE SHOWN IN TABLE BELOW.

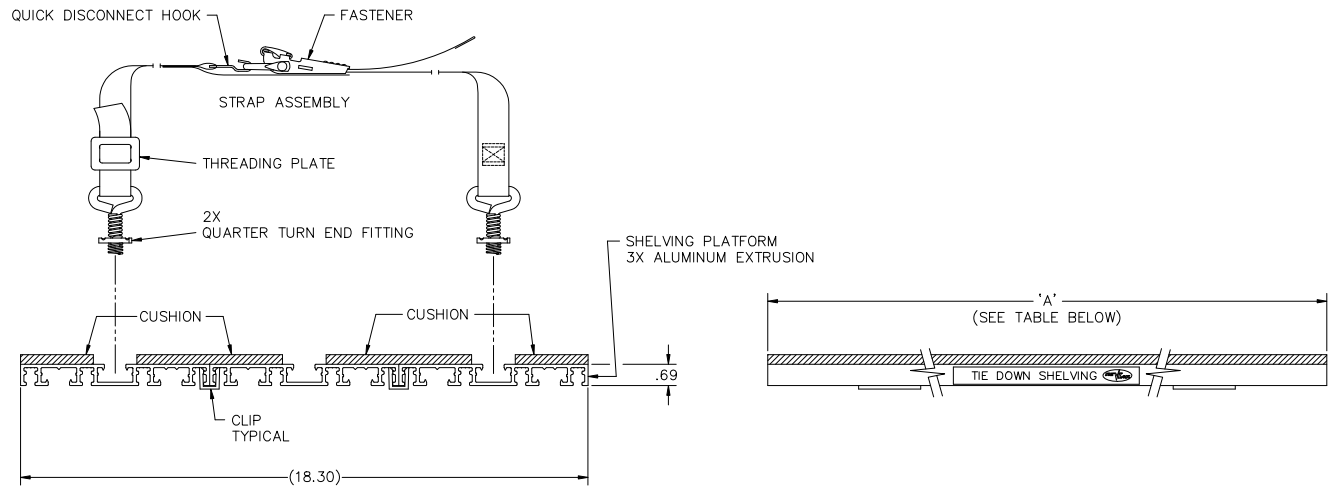

PART NO.	DIM 'A' ±.10	PARTS LIST	
		QUANTITY PER ASSEMBLY	
KE18-2400	24.00	2	STRAP ASSEMBLY
KE18-2800	28.00	3	STRAP ASSEMBLY
KE18-3000	30.00	3	STRAP ASSEMBLY
KE18-3500	35.00	3	STRAP ASSEMBLY
KE18-3600	36.00	3	STRAP ASSEMBLY
KE18-4200	42.00	4	STRAP ASSEMBLY
KE18-4800	48.00	4	STRAP ASSEMBLY
KE18-6000	60.00	5	STRAP ASSEMBLY
KE18-6600	66.00	5	STRAP ASSEMBLY
KE18-7200	72.00	6	STRAP ASSEMBLY
KE18-8400	84.00	7	STRAP ASSEMBLY
KE18-9600	96.00	8	STRAP ASSEMBLY

SPECIFICATION CONTROL DRAWING

INTERPRET DIMENSIONS AND TOLERANCES IN ACCORDANCE WITH ASME Y14.5M-1982 UNLESS OTHERWISE SPECIFIED DIMENSIONS ARE IN INCHES TOLERANCES: DECIMALS .005 .010 .015 FRACTIONS .005 .010 .015 ANGLES ±.5° DO NOT SCALE DRAWING		CONTRACT NO. DATE DRAWN CHECKED APPROVED MANUFACTURING CUSTOMER	DATE 5-1-96 2-8-05 2-8-05	TITLE SHELVING	SIZE D 08992	FSCM NO. DOW. NO. KE18	REV B
PART DASH NO. NEXT QTY. REQD PER ASSY. FINAL NEXT ASSY. USED ON APPLICATION	SIMILAR TO ACT. WT. CALC. WT.	SCALE 1/2 RELEASE DATE	SHEET 1 OF 1	FILE KE18	GGM CONTAINER CONTROLS, INC. P.O. BOX 40020 - TUCSON, ARIZONA 85717-0020		