

8 7 6 5 4 3 2 1

THIS DOCUMENT CONTAINS PROPRIETARY INFORMATION AND EXCEPT WITH WRITTEN PERMISSION BY AGM CONTAINER CONTROLS, INC. SUCH INFORMATION SHALL NOT BE PUBLISHED, DISCLOSED TO OTHERS OR USED FOR ANY PURPOSE AND THE DOCUMENT SHALL NOT BE DUPLICATED IN WHOLE OR IN PART.

REVISIONS				
ZONE	LTR.	DESCRIPTION	DATE	APPROVED

NOTES:

1. DESCRIPTION: SHELVING KIT, SEE PARTS LIST FOR DESCRIPTION AND QUANTITY OF COMPONENTS SUPPLIED WITH EACH KIT. SHELVING KIT IS SUPPLIED PARTIALLY ASSEMBLED AND REQUIRES SOME ASSEMBLY AT POINT OF INSTALLATION. CLIPS ARE PROVIDED FOR TEMPORARY USE DURING SHIPMENT AND ASSEMBLY AND MAY BE REMOVED OR RELOCATED TO FACILITATE ASSEMBLY. END CAPS MUST BE ATTACHED TO SHELVING PLATFORM FOR PROPER ALIGNMENT AND STRUCTURAL SUPPORT.

2. MATERIALS:

- 2.1 SHELVING PLATFORM: ALUMINUM ALLOY EXTRUSION 6.102 +.030 -.054 WIDE, (3) EACH.
- 2.2 CUSHION: COMMERCIAL QUALITY, CLOSED CELL POLYVINYL CHLORIDE FOAM. UNCOMPRESSED THICKNESS APPROXIMATELY .38 INCH. CUSHION BONDED TO SHELVING PLATFORM WITH PERMANENT ACRYLIC PRESSURE SENSITIVE ADHESIVE.
- 2.3 END CAP, AND CLIP: ALUMINUM ALLOY.

3. ASSEMBLY PROCEDURE:

- 3.1 INSERT SCREW HEX HEAD INTO APPROPRIATE GROOVES IN EXTRUSIONS AS SHOWN.
- 3.2 ATTACH END CAPS AT BOTH ENDS OF SHELVING.
- 3.3 INSTALL MS21042-4 NUTS, ONTO SCREWS AND TIGHTEN WITH 30 TO 50 INCH POUNDS OF TORQUE.
- 4. SHELVING MAY BE SUPPLIED IN LENGTHS OTHER THAN THOSE SHOWN IN TABLE BELOW.

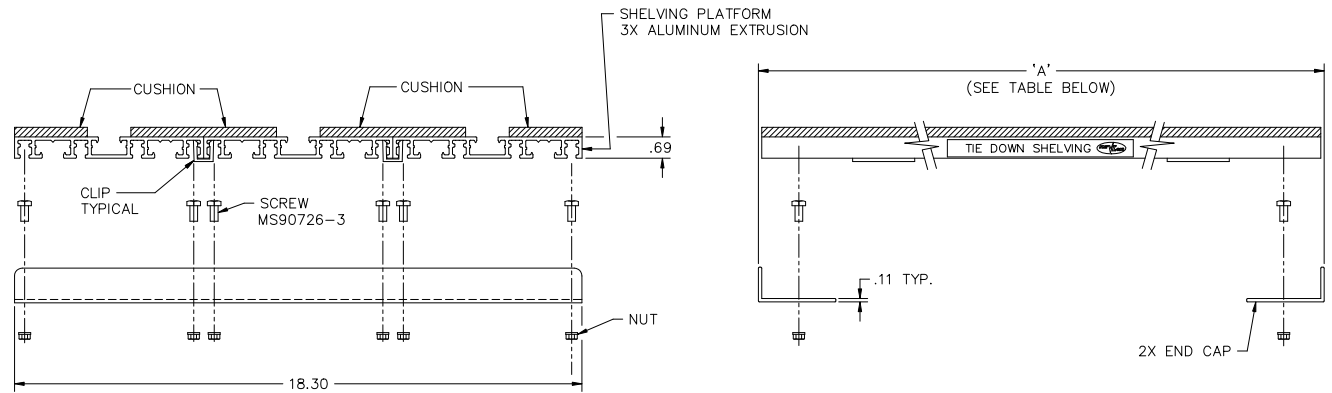

PART NO.	DIM 'A' ±.10	PARTS LIST - QUANTITY PER ASSEMBLY		
		END CAP	MS21042-4 NUT	MS90726-3 SCREW
KD18-2400	24.00	2	12	12
KD18-2800	28.00	2	12	12
KD18-3000	30.00	2	12	12
KD18-3500	35.00	2	12	12
KD18-3600	36.00	2	12	12
KD18-4200	42.00	2	12	12
KD18-4800	48.00	2	12	12
KD18-6000	60.00	2	12	12
KD18-6600	66.00	2	12	12
KD18-7200	72.00	2	12	12
KD18-8400	84.00	2	12	12
KD18-9600	96.00	2	12	12

SPECIFICATION CONTROL DRAWING

INTERPRET DIMENSIONS AND TOLERANCES IN ACCORDANCE WITH ASME Y14.5M-1982 UNLESS OTHERWISE SPECIFIED DIMENSIONS ARE IN INCHES DECIMALS .XXX ±.010 ANGLES ±.5° DO NOT SCALE DRAWING		CONTRACT DATE L. HARTSIG 5-1-96 CHECK P. LANE 2-8-05 APPROVED P. LANE 2-8-05 MANUFACTURING		GGM CONTAINER CONTROLS, INC. P.O. BOX 40020 - TUCSON, ARIZONA 85717-0020 SHELVING	
PART DASH NO. NEXT QTY. REQD PER ASSY. FINAL NEXT ASSY. USED ON APPLICATION		SCALE 1/2 RELEASE DATE SHEET 1 OF 1		FSCM NO. 08992 Dwg. No. KD18 REV B	