

THIS DOCUMENT CONTAINS PROPRIETARY INFORMATION AND EXCEPT WITH WRITTEN PERMISSION BY AGM CONTAINER CONTROLS, INC. SUCH INFORMATION SHALL NOT BE PUBLISHED, DISCLOSED TO OTHERS OR USED FOR ANY PURPOSE AND THE DOCUMENT SHALL NOT BE DUPLICATED IN WHOLE OR IN PART.

REVISIONS				
ZONE	LTR.	DESCRIPTION	DATE	APPROVED

D
C
B
A

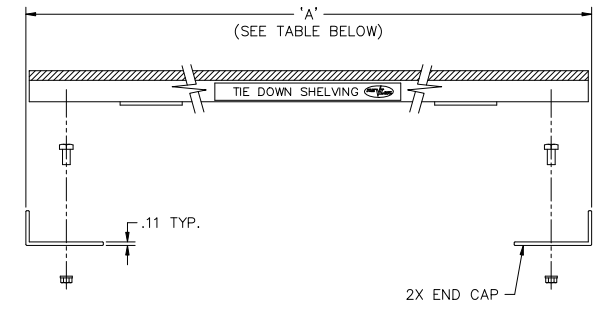
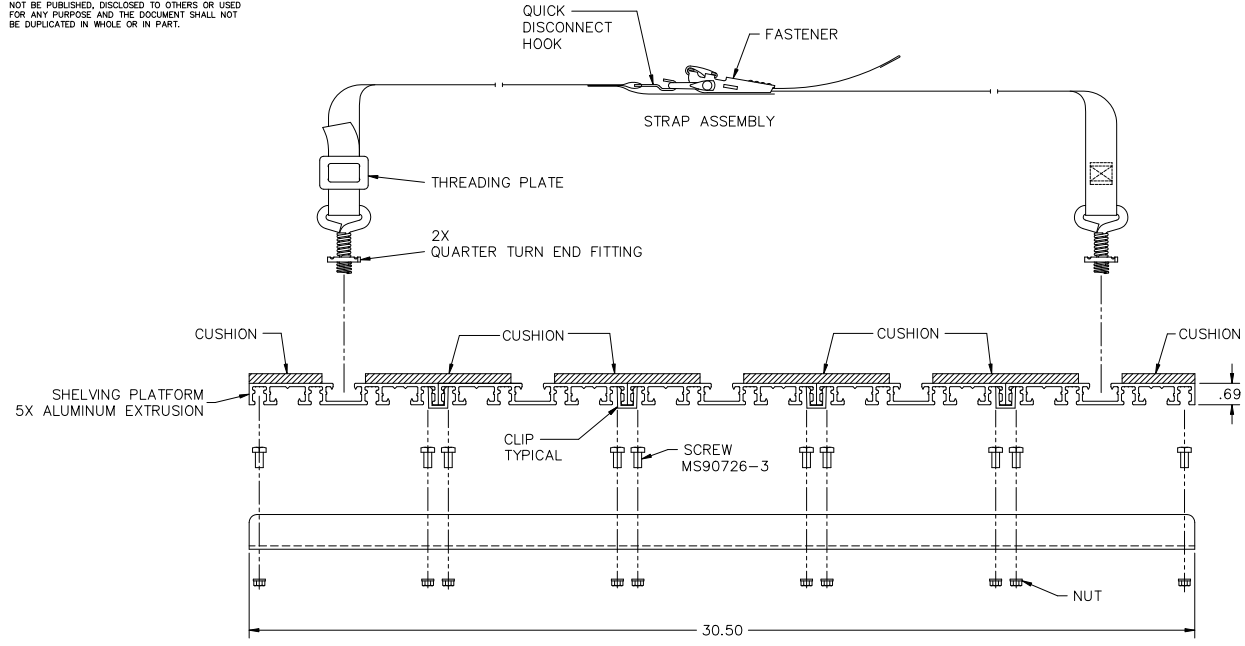

- NOTES:
- DESCRIPTION: SHELVING KIT, SEE PARTS LIST FOR DESCRIPTION AND QUANTITY OF COMPONENTS SUPPLIED WITH EACH KIT. SHELVING KIT IS SUPPLIED PARTIALLY ASSEMBLED AND REQUIRES SOME ASSEMBLY AT POINT OF INSTALLATION. CLIPS ARE PROVIDED FOR TEMPORARY USE DURING SHIPMENT AND ASSEMBLY AND MAY BE REMOVED OR RELOCATED TO FACILITATE ASSEMBLY. END CAPS MUST BE ATTACHED TO SHELVING PLATFORM FOR PROPER ALIGNMENT AND STRUCTURAL SUPPORT.
 - MATERIALS:
 - SHELVING PLATFORM: ALUMINUM ALLOY EXTRUSION 6.102 +.030 -.054 WIDE, (5) EACH.
 - CUSHION: COMMERCIAL QUALITY, CLOSED CELL POLYVINYL CHLORIDE FOAM. UNCOMPRESSED THICKNESS APPROXIMATELY .38 INCH. CUSHION BONDED TO SHELVING PLATFORM WITH PERMANENT ACRYLIC PRESSURE SENSITIVE ADHESIVE.
 - END CAP, AND CLIP: ALUMINUM ALLOY.
 - STRAP ASSEMBLY: SEE DRAWING CT1109.

- ASSEMBLY PROCEDURE:
- INSERT SCREW HEX HEAD INTO APPROPRIATE GROOVES IN EXTRUSIONS AS SHOWN.
 - ATTACH END CAPS AT BOTH ENDS OF SHELVING.
 - INSTALL MS21042-4 NUTS, ONTO SCREWS AND TIGHTEN WITH 30 TO 50 INCH POUNDS OF TORQUE.
 - ATTACH STRAP ASSEMBLY TO SHELVING BY INSERTING QUARTER TURN END FITTINGS INTO GROOVES ON PADDED SURFACE. ROTATE END FITTINGS ONE-QUARTER TURN CLOCKWISE TO LOCK IN PLACE. STRAP ASSEMBLY MAY BE SEPARATED BY REMOVING QUICK DISCONNECT HOOK FROM WIRE END OF FASTENER. DO NOT UNLACE WEBBING FROM FASTENER. FASTENER MAY BE CENTERED ALONG STRAP BY SLIDING WEBBING THROUGH THREADING PLATE.
 - SHELVING MAY BE SUPPLIED IN LENGTHS OTHER THAN THOSE SHOWN IN TABLE BELOW.

PART NO.	DIM 'A' ±.10	PARTS LIST - QUANTITY PER ASSEMBLY			
		END CAP	STRAP ASSY	MS21042-4 NUT	MS90726-3 SCREW
KC30-2400	24.00	2	2	20	20
KC30-2800	28.00	2	3	20	20
KC30-3000	30.00	2	3	20	20
KC30-3500	35.00	2	3	20	20
KC30-3600	36.00	2	3	20	20
KC30-4200	42.00	2	4	20	20
KC30-4800	48.00	2	4	20	20
KC30-6000	60.00	2	5	20	20
KC30-6600	66.00	2	5	20	20
KC30-7200	72.00	2	6	20	20
KC30-8400	84.00	2	7	20	20
KC30-9600	96.00	2	8	20	20

SPECIFICATION CONTROL DRAWING

INTERPRET DIMENSIONS AND TOLERANCES IN INCHES UNLESS OTHERWISE SPECIFIED DECIMALS: .XXX ±.010 ANGLES: ±.5° DO NOT SCALE DRAWING		CONTRACT DATE: 4-13-98 DRAWN BY: L. HARTSIG CHECKED BY: P. LANE APPROVED BY: P. LANE MANUFACTURING: 2-8-05		GGM CONTAINER CONTROLS, INC. P.O. BOX 40020 - TUCSON, ARIZONA 85717-0020 SHELVING	
PART DASH NO. NEXT QTY. REQD PER ASSY. FINAL NEXT ASSY. USED ON APPLICATION	DIMENSION TO FCT. WT. CALC. WT.	SCALE: 1/2 RELEASE DATE	FSCM NO.: 08992 Dwg. NO.: KC30	REV: B	SHEET 1 OF 1