

THIS DOCUMENT CONTAINS PROPRIETARY INFORMATION AND EXCEPT WITH WRITTEN PERMISSION BY AGM CONTAINER CONTROLS, INC. SUCH INFORMATION SHALL NOT BE PUBLISHED, DISCLOSED TO OTHERS OR USED FOR ANY PURPOSE AND THE DOCUMENT SHALL NOT BE DUPLICATED IN WHOLE OR IN PART.

REVISIONS				
ZONE	LTR.	DESCRIPTION	DATE	APPROVED

D
C
B
A

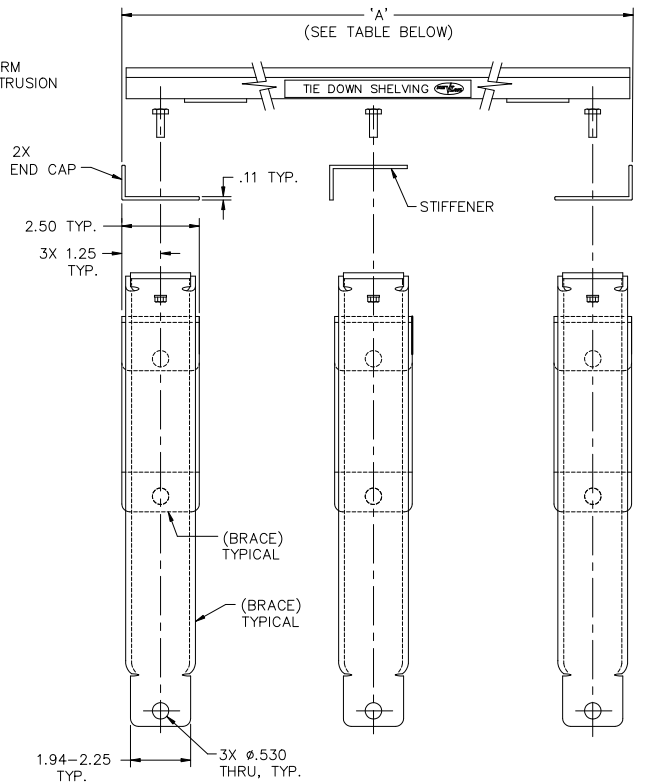
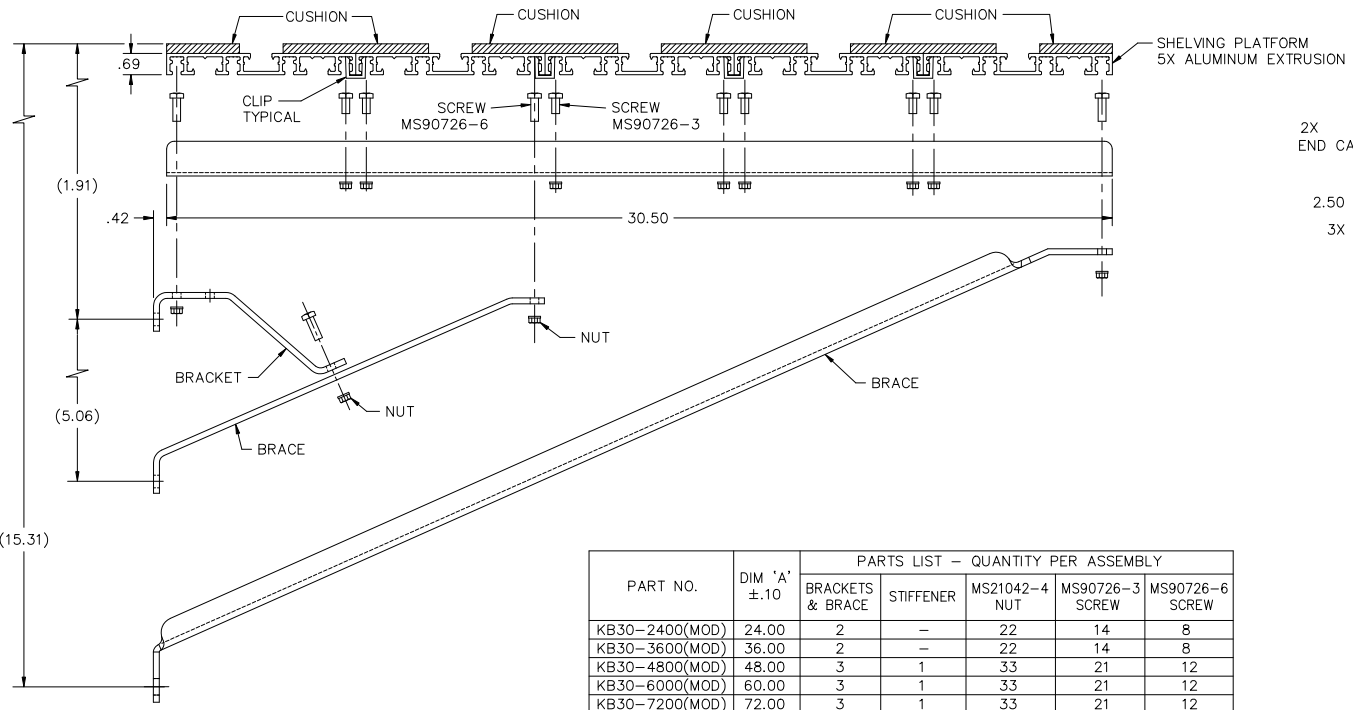

PART NO.	DIM 'A' ±.10	PARTS LIST - QUANTITY PER ASSEMBLY				
		BRACKETS & BRACE	STIFFENER	MS21042-4 NUT	MS90726-3 SCREW	MS90726-6 SCREW
KB30-2400(MOD)	24.00	2	-	22	14	8
KB30-3600(MOD)	36.00	2	-	22	14	8
KB30-4800(MOD)	48.00	3	1	33	21	12
KB30-6000(MOD)	60.00	3	1	33	21	12
KB30-7200(MOD)	72.00	3	1	33	21	12

NOTES:

- DESCRIPTION: SHELVING KIT, SEE PARTS LIST FOR DESCRIPTION AND QUANTITY OF COMPONENTS SUPPLIED WITH EACH KIT. SHELVING KIT IS SUPPLIED PARTIALLY ASSEMBLED AND REQUIRES SOME ASSEMBLY AT POINT OF INSTALLATION. THE STIFFENERS SHALL BE LOCATED AT EACH END AND IN CENTER OF SHELVING PLATFORM FOR PROPER ALIGNMENT AND STRUCTURAL SUPPORT. CLIPS ARE PROVIDED FOR TEMPORARY USE DURING SHIPMENT AND ASSEMBLY. THE CLIPS MAY BE REMOVED OR RELOCATED TO FACILITATE ASSEMBLY OF STIFFENERS.
- MATERIALS:
 - SHELVING PLATFORM: ALUMINUM ALLOY EXTRUSION 6.102 +.030 -.054 WIDE, (5) EACH.
 - CUSHION: COMMERCIAL QUALITY, CLOSED CELL POLYVINYL CHLORIDE FOAM. UNCOMPRESSED THICKNESS APPROXIMATELY .38 INCH. CUSHION BONDED TO SHELVING PLATFORM WITH PERMANENT ACRYLIC PRESSURE SENSITIVE ADHESIVE.
 - BRACKET, BRACE, STIFFENER, AND CLIP: ALUMINUM ALLOY.
- ASSEMBLY PROCEDURE:
 - INSERT SCREW HEX HEAD INTO APPROPRIATE GROOVES IN EXTRUSIONS AS SHOWN. REMOVE OR RELOCATE CLIPS AS REQUIRED FOR INSTALLATION OF SCREWS FOR USE WITH STIFFENERS. NOTE THE VARIATION OF SCREW LENGTHS. INSERT ALL SCREWS BEFORE PROCEEDING.
 - STIFFENER(S) SHALL BE LOCATED AT EACH END AND EQUALLY SPACED ALONG SHELVING, OR IN LINE WITH NEXT ASSEMBLY SUPPORTING STRUCTURE. INSTALL BRACKET(S) AND BRACE(S) AT THE SAME LOCATION AND AT SAME TIME AS STIFFENERS.
 - INSTALL MS21042-4 NUTS, ONTO SCREWS AND TIGHTEN WITH 30 TO 50 INCH POUNDS OF TORQUE.
 - SHELVING MAY BE SUPPLIED IN LENGTHS OTHER THAN THAT SHOWN IN TABLE ABOVE.

SPECIFICATION CONTROL DRAWING

INTERPRET DIMENSIONS AND TOLERANCES IN INCHES UNLESS OTHERWISE SPECIFIED		CONTRACT		AGM CONTAINER CONTROLS, INC. P.O. BOX 40020 - TUCSON, ARIZONA 85717-0020	
DECIMALS .001 ±.005 .000 ±.010 ANGLES ±.5°		DRAWN L. HARTSIG	DATE 5-11-98	TITLE SHELVING	
DO NOT SCALE DRAWING		CHECK P. LANE	APPROVED P. LANE	SIZE D 08992	
PART QTY. FINAL NEXT FINAL NEXT ASSY. USED ON DASH NO. PER ASSY. APPLICATION		MANUFACTURING P. LANE	CUSTOMER	FSCM NO. 08992	Dwg. NO. KB30(MOD)
		SCALE 1/2		SHEET 1 OF 1	