

THIS DOCUMENT CONTAINS PROPRIETARY INFORMATION AND EXCEPT WITH WRITTEN PERMISSION BY AGM CONTAINER CONTROLS, INC. SUCH INFORMATION SHALL NOT BE PUBLISHED, DISCLOSED TO OTHERS OR USED FOR ANY PURPOSE AND THE DOCUMENT SHALL NOT BE DUPLICATED IN WHOLE OR IN PART.

REVISIONS				
ZONE	LTR.	DESCRIPTION	DATE	APPROVED

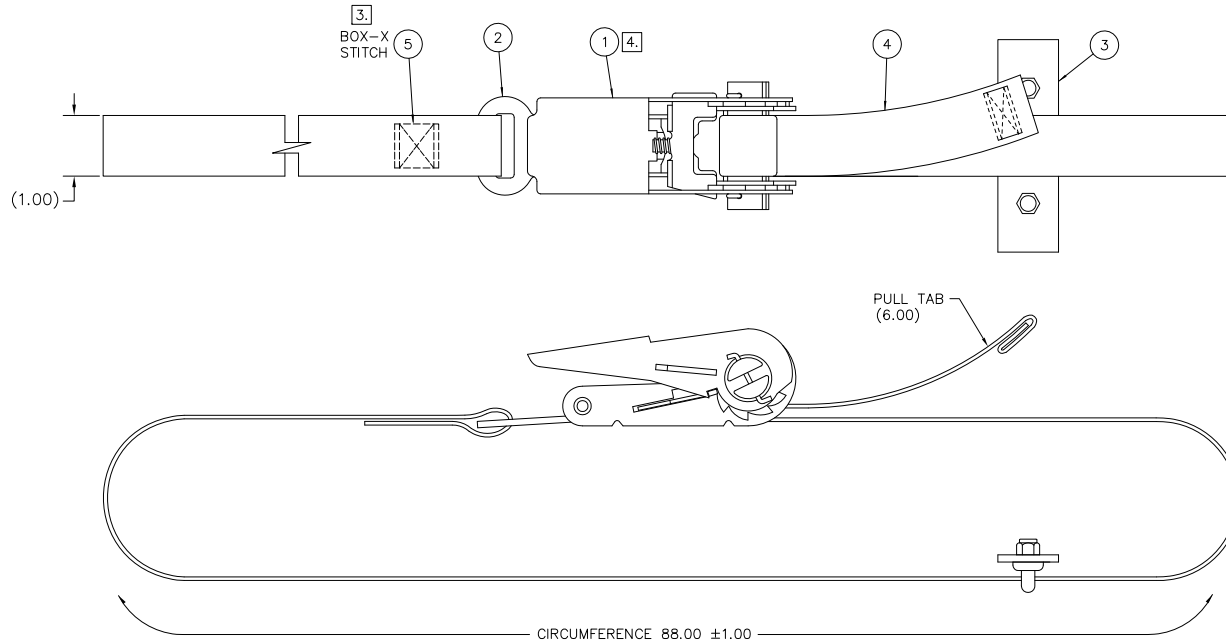

NOTES:

1. MINIMUM TENSILE BREAKING STRENGTH OF COMPLETE ASSEMBLY SHALL BE 1200 POUNDS. SAFE WORKING LOAD, 400 POUNDS MAXIMUM.
2. WEBBING ENDS SHALL BE SEALED BEFORE STITCHING.
3. STITCHING SHALL BE IAW FED-STD-751, TYPE 301. STITCH PATTERN SHALL BE SUFFICIENT TO MEET THE REQUIREMENTS OF NOTE 1 ABOVE.
4. FASTENER SHALL BE A RATCHET TYPE DEVICE THAT APPLIES TENSION TO WEBBING WHEN MANUALLY OPERATED.
5. FINISH: STEEL COMPONENTS, ZINC PLATED, BRONZE OR CLEAR CHROMATE.

SPECIFICATION CONTROL DRAWING

A/R	08992	970033	THREAD	POLYESTER, SIZE FF, COLOR BLACK	5
A/R	08992	W1404-BK	WEBBING	BULKED NYLON, COLOR BLACK	4
1	08992	825640	STRAP RETAINER	STEEL AND ALUMINUM COMPONENTS [5]	3
1	08992	K467	QUICK DISCONNECT	COLD ROLLED STEEL [5]	2
1	08992	K428	FASTENER	COLD ROLLED STEEL [5]	1
QTY. REQ'D.	FSCM NO.	PART OR IDENTIFYING NO.	NOMENCLATURE OR DESCRIPTION	MATERIAL / SPECIFICATION	ITEM NO.

PARTS LIST

PART DASH NO.		QTY. REQ'D PER ASSY.	NEXT FINAL	NEXT ASSY.	USED ON	APPLICATION	SMALLER TO	ADJ. WT. CALC. WT.	CUSTOMER
<p>INTERPRET DIMENSIONS AND TOLERANCES IAW ASME Y14.5M-1982 UNLESS OTHERWISE SPECIFIED DIMENSIONS ARE IN INCHES TOLERANCES: DECIMALS .XX ±.015 .XXX ±.010 ANGLES .5° FINISH [5]</p> <p>DO NOT SCALE DRAWING</p>						<p>CHECKED DATE M. ONTIVEROS 1-15-07</p> <p>DATE E. ZUERCHER 1-16-07</p> <p>DATE E. ZUERCHER 1-16-07</p>		<p>GM CONTAINER CONTROLS, INC. P.O. BOX 40020 - TUCSON, ARIZONA 85717-0020</p> <p>TITLE STRAP ASSEMBLY</p>	
SCALE		FSCM NO.		DWG. NO.		REV		SHEET	
D 1/1		08992		CT2961-18		-		1 OF 1	