

THIS DOCUMENT CONTAINS PROPRIETARY INFORMATION AND EXCEPT WITH WRITTEN PERMISSION BY AGM CONTAINER CONTROLS, INC. SUCH INFORMATION SHALL NOT BE PUBLISHED, DISCLOSED TO OTHERS OR USED FOR ANY PURPOSE AND THE DOCUMENT SHALL NOT BE DUPLICATED IN WHOLE OR IN PART.

REVISIONS				
ZONE	LTR.	DESCRIPTION	DATE	APPROVED
	M	ADVANCED REVISION TO AGREE WITH MIL. PML	12-27-02	ROC
B1	N	COLOR OF INK, ITEM 9, WAS WHITE IN ERROR. JMO	2-17-03	PML
A3	P	PART LIST TABLE: FASTENER & END FITTING WERE CARBON STEEL, PAD WAS IAW MIL SPEC 7-10-09 JMO	7-13-09	EJZ
A8,B3	R	NOTE 6: REMOVED FINISH SPEC'S, INK P/N WAS 911002 JMO	10-14-10	EJZ

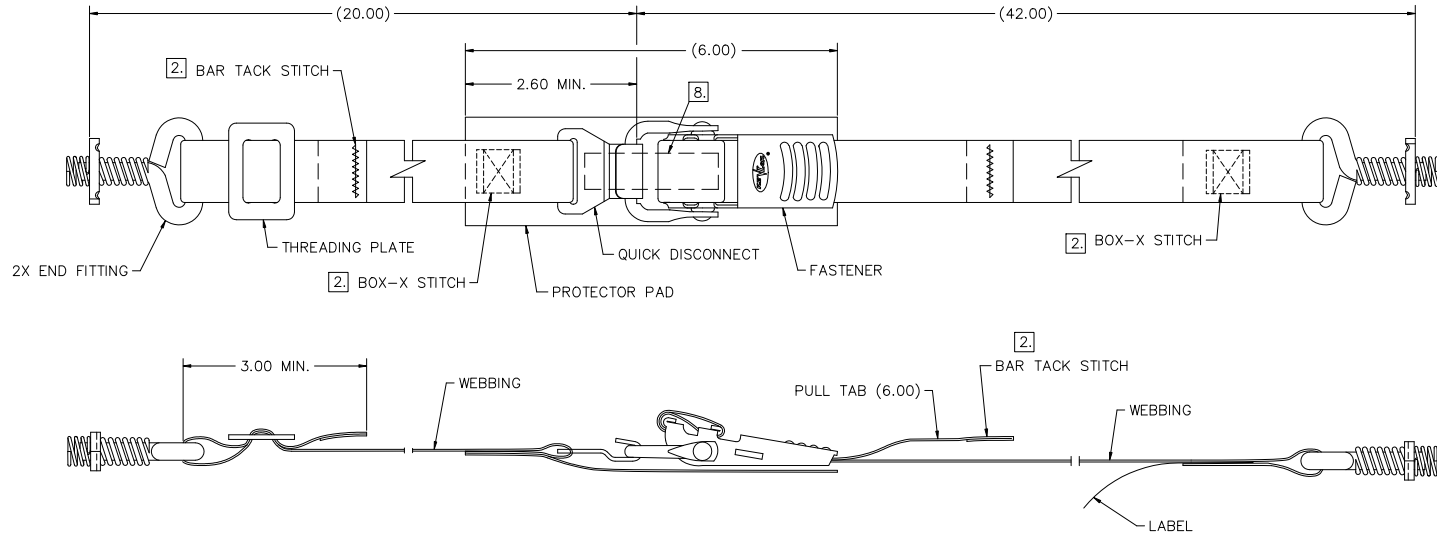

NOTES:

1. DESCRIPTION: STRAP ASSEMBLY, EQUIPMENT TIE-DOWN, ADJUSTABLE FROM 11 TO 60 INCHES.
2. STITCH IAW FED-STD-751, TYPE 301. PATTERN SHALL BE SUFFICIENT TO MEET REQUIREMENTS OF NOTE 3.
3. MINIMUM TENSILE STRENGTH OF COMPLETE ASSEMBLY SHALL BE 300 POUNDS.
4. WEBBING ENDS SHALL BE SEARED BEFORE STITCHING.
5. FASTENER SHALL BE AN OVER CENTER LOCKING DEVICE THAT APPLIES TENSION TO WEBBING WHEN MANUALLY CLOSED.
6. FINISH: STEEL COMPONENTS ZINC PLATED, BRONZE CHROMATE FINISH.
7. IDENTIFICATION SHALL BE IAW MIL-STD-130 WITH THE FOLLOWING INFORMATION:  
08992-CT1109  
K1012766-7
8. MARKING SHALL BE BY STENCIL, SILK SCREEN, OR RUBBER STAMP WITH PERMANENT INK, ITEM 9, ON TOP SURFACE OF PROTECTOR PAD, ITEM 8.

SPECIFICATION CONTROL DRAWING

1	08992	815399	LABEL	INSTRUCTION/CAUTION LABEL	10
A/R	08992	911001	INK, EPOXY	IAW MIL-I-43553, COLOR BLACK	9
A/R	08992	K439	PROTECTOR PAD	NYLON, COLOR GREY	8
A/R	08992	970033	THREAD	POLYESTER IAW V-T-285, TYPE II, CLASS 1, SIZE FF, SUBCLASS A, COLOR BLACK	7
1	08992	W400-GR (52.00)	WEBBING	NYLON IAW MIL-W-4088, CLASS 2, TYPE XVII, COLOR GREY, COND. R, IAW MIL-W-27265	6
1	08992	W400-GR (25.00)	WEBBING	NYLON IAW MIL-W-4088, CLASS 2, TYPE XVII, COLOR GREY, COND. R, IAW MIL-W-27265	5
2	08992	K490	END FITTING	CARBON STEEL	4
1	08992	K442	THREADING PLATE	COLD ROLLED STEEL	3
1	08992	K462	QUICK DISCONNECT	COLD ROLLED STEEL	2
1	08992	K417	FASTENER	CARBON STEEL	1

PARTS LIST

INTERPRET DIMENSIONS AND TOLERANCES IAW ASME Y14.5M-1982 UNLESS OTHERWISE SPECIFIED DIMENSIONS ARE IN INCHES DECIMALS .XXX ±.015 .XXXX ±.010 ANGLES ±.5° TOLERANCES:		CONTRACT DATE L.HARTSIG 7-21-92 CHECKED B.CROWLEY 7-21-92 APPROVED B.CROWLEY 7-21-92 MANUFACTURING		<b>AGM CONTAINER CONTROLS, INC.</b> P.O. BOX 40020 - TUCSON, ARIZONA 85717-0020 <b>STRAP ASSEMBLY</b>	
DO NOT SCALE DRAWING FINISH: 6.		SCALE: 1/1 RELEASE DATE:		SIZE: FSCM NO. 08992 DWG. NO. CT1109 REV R	
PART DASH NO.		NEXT QTY. REQD PER ASSY.		NEXT ASSY. APPLICATION	