

4

3

2

1

REVISIONS				
ZONE	LTR.	DESCRIPTION	DATE	APPROVAL

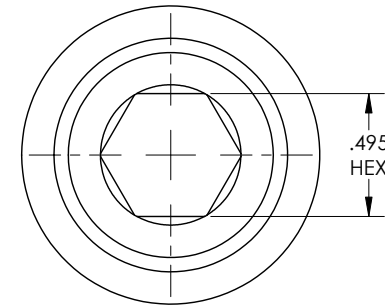
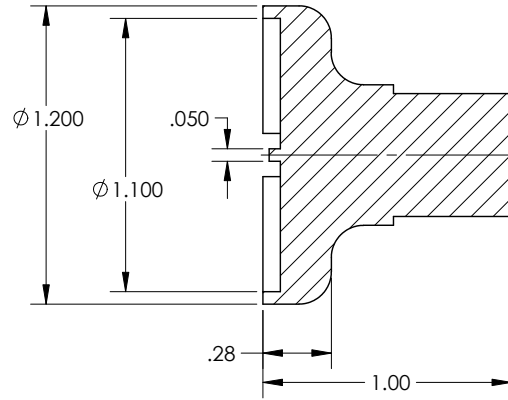
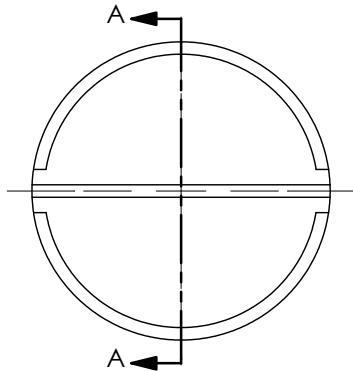
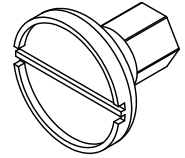

NOTE:

- DESCRIPTION: .050" FLAT BLADE DRIVE. USE THIS TOOL TO FACILITATE INSTALLATION/REMOVAL OF A VARIETY OF AGM PRODUCTS INCLUDING BUT NOT LIMITED TO TA348, TA364, AND TA365 (HUMIDITY INDICATORS, DESICCATORS, OBSERVATION WINDOWS, ETC).
- MATERIAL: STAINLESS STEEL, AISI 303 ALLOY IAW ASTM A582.
- FINISH: STAINLESS STEEL, PASSIVATED

SECTION A-A

				INTERPRET DIMENSIONS AND TOLERANCES IAW ANSI Y14.5M-1994 UNLESS OTHERWISE SPECIFIED DIMENSIONS ARE IN INCHES TOLERANCES: DECIMALS .XX ± .015 ANGLES ± .5° .XXX ± .010		CONTRACT NO.		AGM CONTAINER CONTROLS, INC. P.O. BOX 40020 - TUCSON, ARIZONA 85717-0020			
				DO NOT SCALE DRAWING		DRAWN R.CASAD		DATE 6-4-19			
						CHECK APPROVED		TITLE DRIVER, FLAT BLADE			
						By Patrick M. Lane at 4:50 pm, Jun 04, 2019					
				FINISH		MANUFACTURING		REV. C			
PART DASH NO.		NEXT FINAL		NEXT ASSY.		USED ON		SIZE B		FSCM NO. 08992	
QTY. REQ'D PER ASSY.		APPLICATION		SIMILAR TO		ACT. WT.		DWG. NO. 980401-SS		SCALE 2/1	
								RELEASE DATE		SHEET 1 OF 1	

4

3

2

1