

4

3

2

1

| REVISIONS |      |             |      |          |
|-----------|------|-------------|------|----------|
| ZONE      | LTR. | DESCRIPTION | DATE | APPROVAL |

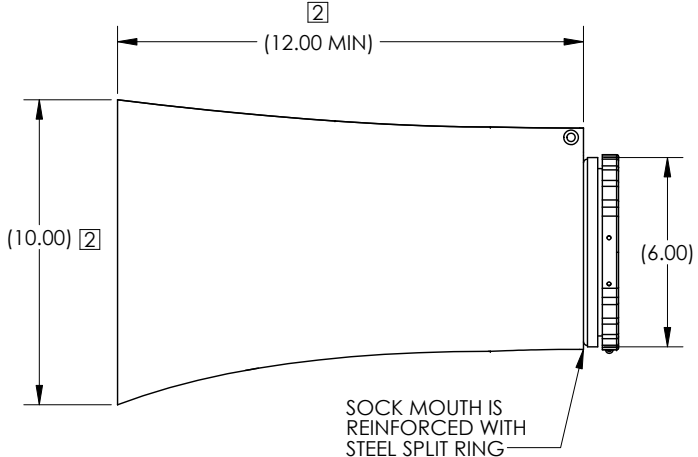
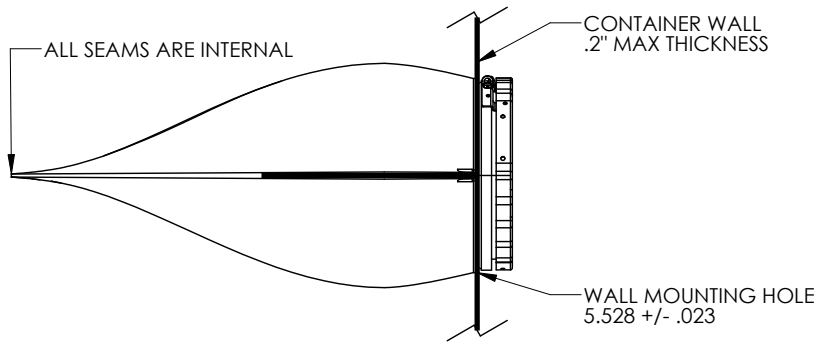
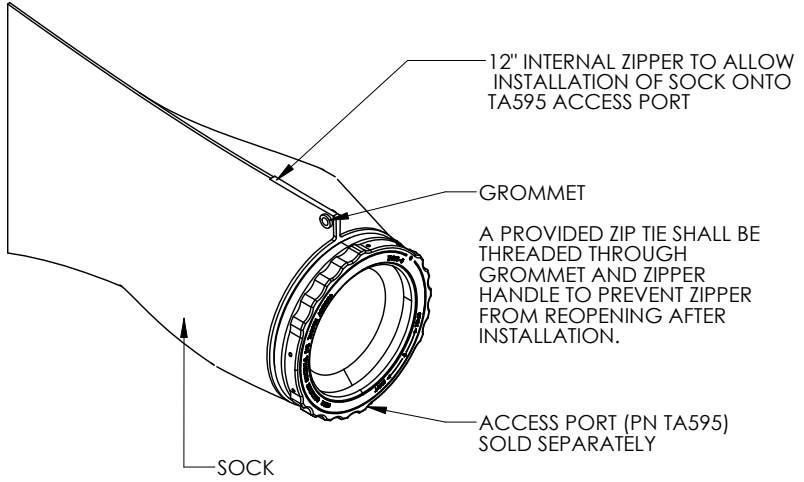

- NOMENCLATURE: DESICCANT SOCK.
- 2 CUSTOM LENGTHS AND WIDTHS AVAILABLE. MINIMUM LENGTH IS 12 INCHES.
- SOCK MATERIAL: COTTON CLOTH FABRIC.
- FOR REFERENCE:  
A SOCK MEASURING 24 INCHES LONG AND 10 INCHES WIDE WILL HOLD UP TO 12 DESI PAK 16-UNIT DESICCANT BAGS.
- ACCESS PORT, PROVIDED SEPARATELY, MAY BE FITTED WITH OBSERVATION WINDOW, HUMIDITY INDICATOR PLUG, OR VALVE. REFER TO DRAWING TA595 FOR DETAILS.

|                      |  |             |  |  |  |  |  |  |  |   |  |
|----------------------|--|-------------|--|--|--|--|--|--|--|---|--|
|                      |  |             |  | INTERPRET DIMENSIONS AND TOLERANCES IAW ANSI Y14.5M-1994<br>UNLESS OTHERWISE SPECIFIED DIMENSIONS ARE IN INCHES<br>TOLERANCES:<br>DECIMALS .XX ± .015    ANGLES ± .5°<br>.XXX ± .010 |  | CONTRACT NO.<br>DRAWN J.BONTRAGER    DATE 1-8-19<br>CHECK<br><b>APPROVED</b><br><i>By Eric Zuercher at 9:03 am, Feb 18, 2019</i> |  | <b>AGM CONTAINER CONTROLS, INC.</b><br>P.O. BOX 40020 - TUCSON, ARIZONA 85717-0020 |  |   |  |
|                      |  |             |  | DO NOT SCALE DRAWING   |  | MANUFACTURING  |  | TITLE<br><b>DESICCANT SOCK</b>   |  |   |  |
| PART DASH NO.        |  | NEXT FINAL  |  | NEXT ASSY.   |  | USED ON  |  | FINISH   |  | SIZE <b>B</b> FSCM NO. <b>08992</b> DWG. NO. <b>TA596-S</b> REV. <b>-</b> |  |
| QTY. REQ'D PER ASSY. |  | APPLICATION |  | SIMILAR TO   |  | ACT. WT.   |  | CALC. WT.  |  | SCALE 1/1    RELEASE DATE    SHEET 1 OF 1                                 |  |

4

3

2

1