

THIS DRAWING IS THE PROPERTY OF BROWNELL LTD. AND MAY NOT BE COPIED OR REPRODUCED WITHOUT THEIR PRIOR WRITTEN PERMISSION

DRG No  
BL/D6290/01-05 INST  
USED ON \_\_\_\_\_

THIRD ANGLE PROJECTION

REMOVE ALL SHARP EDGES UNLESS SPECIFIED

DO NOT SCALE - ASK

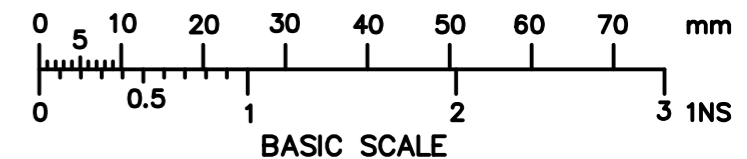

| PART No.    | MODEL | A    | B  | C     | D   | E  | FLANGE F | G   | H   | J   | K   |
|-------------|-------|------|----|-------|-----|----|----------|-----|-----|-----|-----|
| BL/D6290/01 | V     | 82.5 | 57 | 155.5 | 255 | 14 | 1" BSTD  | 205 | 375 | 227 | 127 |
| BL/D6290/02 | W     | 82.5 | 57 | 155.5 | 255 | 14 | 1" BSTD  | 205 | 555 | 407 | 127 |
| BL/D6290/03 | X     | 82.5 | 57 | 155.5 | 255 | 14 | 1" BSTD  | 205 | 735 | 587 | 127 |
| BL/D6290/04 | Y     | 127  | 57 | 184   | 355 | 14 | 1" BSTD  | 306 | 485 | 342 | 178 |
| BL/D6290/05 | Z     | 127  | 57 | 184   | 355 | 14 | 1" BSTD  | 306 | 645 | 502 | 178 |

| PART No.    | THREAD T  | CHARGE  |
|-------------|-----------|---------|
| BL/D6290/01 | 3/4" BSPP | 5 Kg    |
| BL/D6290/02 | 3/4" BSPP | 10 Kg   |
| BL/D6290/03 | 3/4" BSPP | 14.5 Kg |
| BL/D6290/04 | 1" BSPP   | 17.5 Kg |
| BL/D6290/05 | 1" BSPP   | 27.3 Kg |

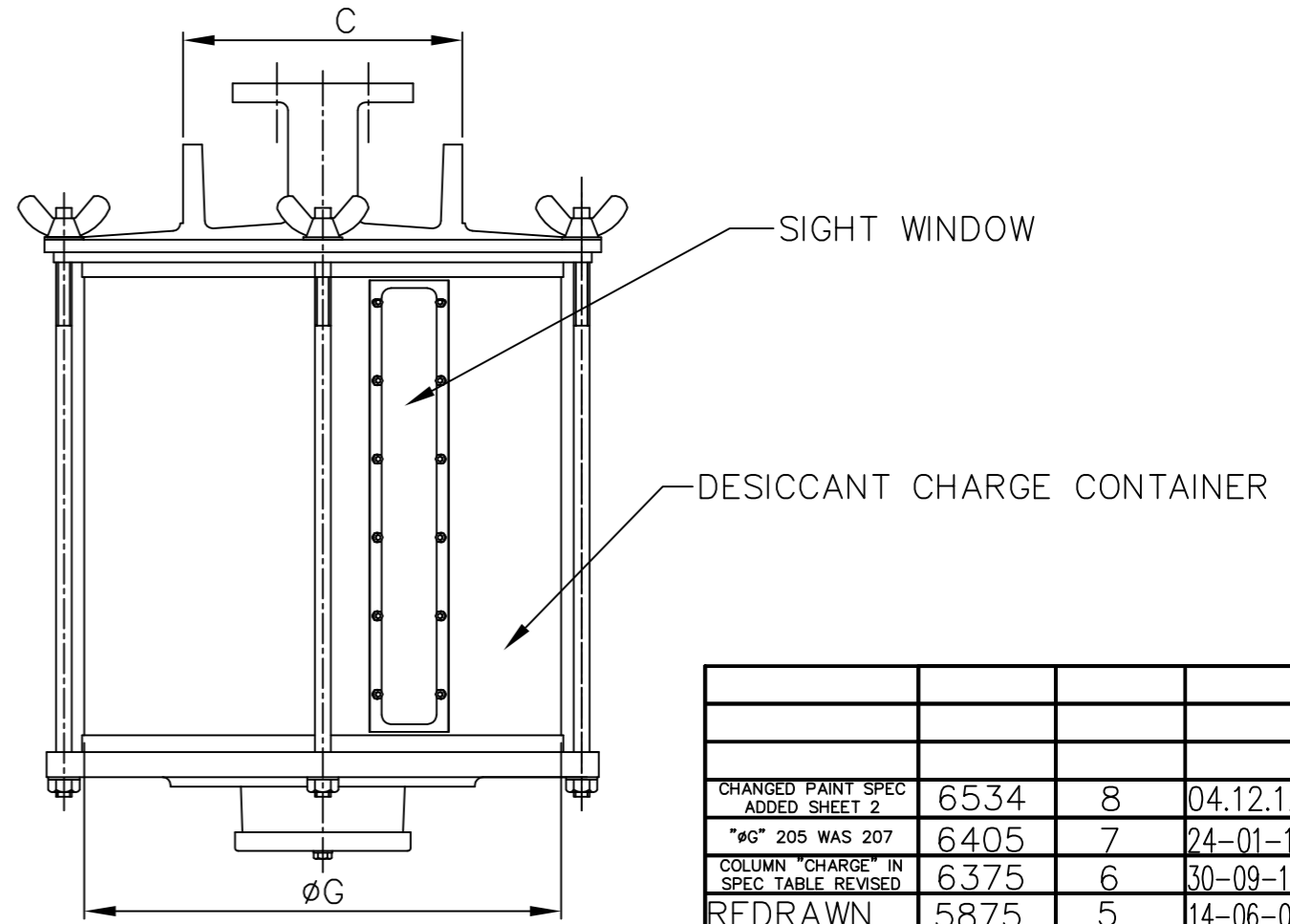
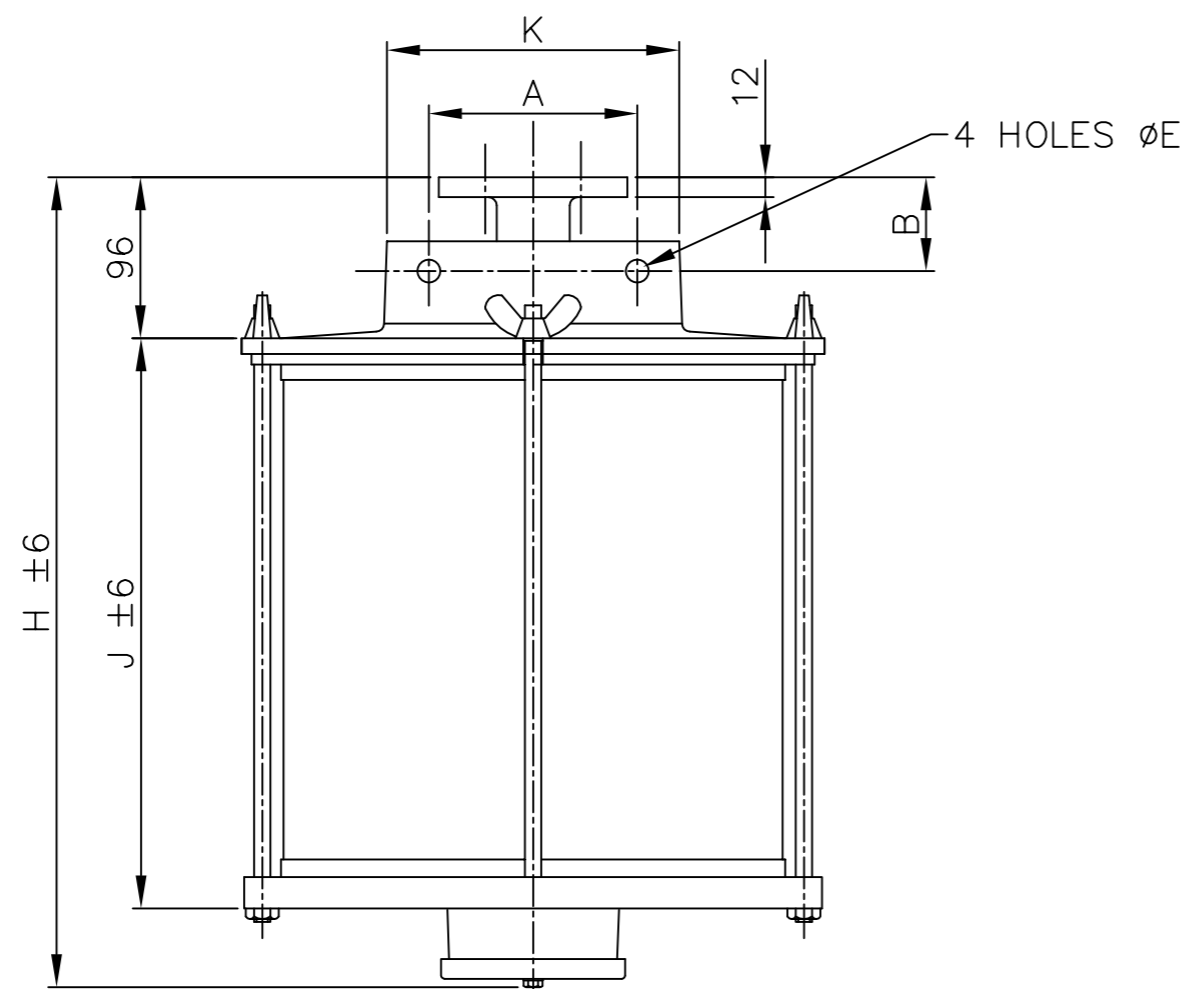
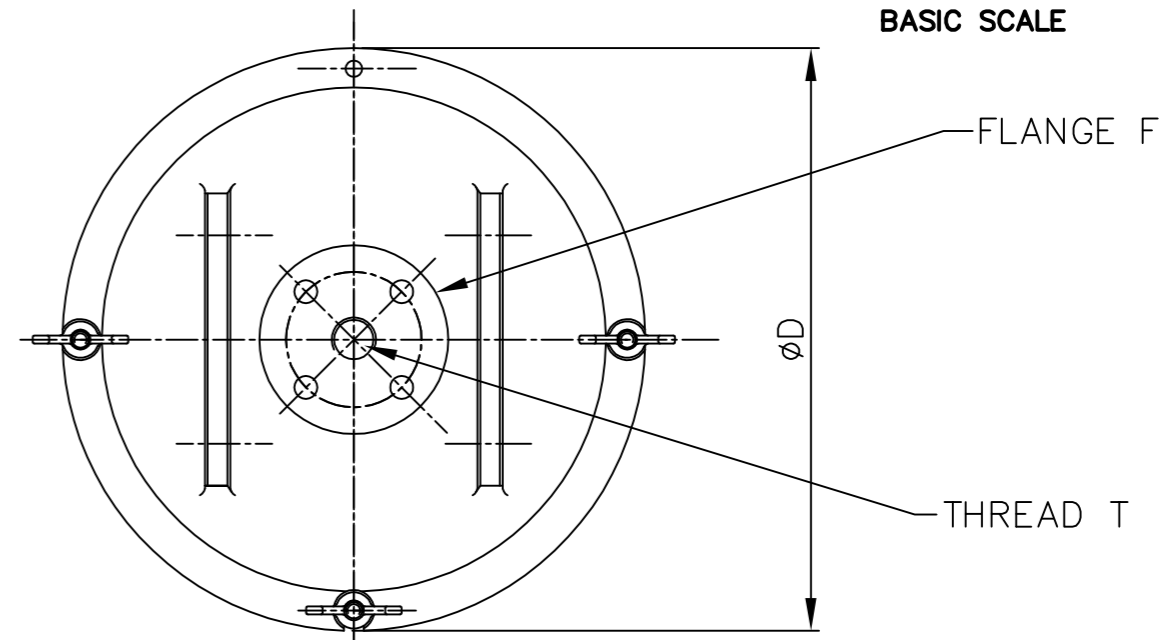

| CHANGE                                | MOD No | ISSUE | DATE     |
|---------------------------------------|--------|-------|----------|
| CHANGED PAINT SPEC ADDED SHEET 2      | 6534   | 8     | 04.12.12 |
| "ØG" 205 WAS 207                      | 6405   | 7     | 24-01-11 |
| COLUMN "CHARGE" IN SPEC TABLE REVISED | 6375   | 6     | 30-09-10 |
| REDRAWN                               | 5875   | 5     | 14-06-05 |

|                                    |   |                     |                               |                                    |             |         |
|------------------------------------|---|---------------------|-------------------------------|------------------------------------|-------------|---------|
| MATERIAL<br>ALUMINIUM & MILD STEEL | PROTECTIVE FINISH<br>ALUM - ANODISE OR EPOXY PAINT<br>M.STEEL-PHOSPHATE | TOLERANCES<br>±3    | TITLE<br>TRANSFORMER BREATHER | RED DOT=ORIGINAL<br>BLACK DOT=COPY | DRAWN<br>PL | CHECKED |
|                                    |   | DIMENSIONS IN in/mm |                               |                                    |             |         |
| EST. WT.                           |   | SURFACE ROUGHNESS   |                               | DRAWING NUMBER                     |             |         |
|                                    |   | SCALE (ORIGINAL)    | 1:5                           | SHEET 1/2                          |             |         |
|                                    |   |                     |                               | BL/D6290/01-05 INST                |             |         |

**BROWNELL Ltd. LONDON NW10 7XF**

DRG No  
BL/D6290/01-05 INST  
USED ON -----

REMOVE ALL SHARP EDGES  
UNLESS SPECIFIED

THIRD ANGLE PROJECTION  
DO NOT SCALE - ASK

INTERPON D1036 - BLACK  
(ALUMINIUM & MILD STEEL)

CLEANING & MAINTENANCING

THE METHOD OF CLEANING IS BY  
REGULAR WASHING OF THE COATING  
USING A SOLUTION OF WARM WATER  
AND MILD DETERGENT. ALL SURFACES  
SHOULD BE CLEANED USING A SOFT  
CLOTH OR SPONGE.  
IF STUBBORN FILM, NO HARSHER THAN  
A NATURAL BRISTLE BRUSH SHOULD BE  
USED TO CLEAN THE SURFACE.

DEPENDENT ON ENVIRONMENTAL  
CONDITIONS THE SURFACE SHOULD BE  
CLEANED AT 3 MONTHLY INTERVALS. IN  
HARSH ENVIRONMENTS MORE FREQUENT  
CLEANING SHOULD TAKE PLACE.

THIS DESIGN IS THE PROPERTY OF BROWNELL  
LTD, AND MAY NOT BE COPIED OR REPRODUCED  
WITHOUT THEIR PRIOR WRITTEN PERMISSION

|  |  |   |             |         |          |
|--|--|---|-------------|---------|----------|
| MATERIAL<br>-----  | PROTECTIVE FINISH<br>-----             |   |             |         |          |
|  |  | ORIGINAL  |             | 1       | 04.12.12 |
| EST. WT. -----   | SURFACE ROUGHNESS                      | CHANGE  | MOD No      | ISSUE   | DATE     |
| DIMS IN -----  | -----                                  | TOLERANCES<br>(UNLESS STATED)                       | LINEAR      | ANGULAR |          |
| SCALE -----  |  |   | -----       | -----   |          |
|  RED DOT = ORIGINAL<br>BLACK DOT = COPY | <b>BROWNELL LTD</b><br>LONDON NW10 7XF |   | DRAWN<br>PL | CHECKED |          |
| TITLE<br>FINISH SPECIFICATION<br>& MAINTENANCE   |  | DRAWING No. <u>SHEET 2/2</u><br>BL/D6290/01-05 INST |             |         |          |