

THIS DOCUMENT CONTAINS PROPRIETARY INFORMATION AND EXCEPT WITH WRITTEN PERMISSION BY AGM CONTAINER CONTROLS, INC. SUCH INFORMATION SHALL NOT BE PUBLISHED, DISCLOSED TO OTHERS OR USED FOR ANY PURPOSE AND THE DOCUMENT SHALL NOT BE DUPLICATED IN WHOLE OR IN PART.

REVISIONS				
ZONE	LTR.	DESCRIPTION	DATE	APPROVED

NOTES:

- DESCRIPTION: SHELVING KIT, WITH WRITING SURFACE, PULL OUT KEYBOARD TRAY, AND TIE DOWN STRAPS. SHELVING KIT IS SUPPLIED PARTIALLY ASSEMBLED AND REQUIRES ATTACHMENT OF BRACKETS AND BRACES AT TIME OF INSTALLATION. LOCATION OF BRACKETS AND BRACES ON UNDERSIDE OF SHELF MAY BE ADJUSTED SLIGHTLY TO LINE UP WITH MOUNTING REQUIREMENTS.
- MATERIALS:
 - SHELVING PLATFORM: 6061-T6 ALUMINUM EXTRUSION IAW SAE-AMS-QQ-A-200/8; 6.102 +.030 -.054 WIDE, (4) EACH. ALT. 6005-T5 IAW ASTM B221.
 - CUSHION: COMMERCIAL QUALITY, CLOSED CELL POLYVINYL CHLORIDE FOAM. UNCOMPRESSED THICKNESS APPROXIMATELY .38 INCH. CUSHION BONDED TO SHELVING PLATFORM WITH PERMANENT ACRYLIC PRESSURE SENSITIVE ADHESIVE.
 - BRACKET, BRACE, END CAP, AND CLIP: 6061-T4 OR -T6 ALUMINUM ALLOY IAW SAE-AMS-QQ-A-200/8, OR ASTM B221. ALT. 5052-H32.
 - WRITING SURFACE AND PULL OUT KEYBOARD TRAY: POWDER COATED STEEL.
 - STRAP ASSEMBLY: SEE DRAWING CT1109.

3. ASSEMBLY PROCEDURE:

- ATTACH BRACKET TO SHORT BRACE USING LONG SCREW AND SELF LOCKING NUT, (2) PLACES. REMOVE LOOSE SELF LOCKING NUTS FROM LONG SCREWS ON BOTH END CAPS. PLACE BRACKET, SHORT BRACE AND LONG BRACE ON LONG SCREWS, AS SHOWN. INSTALL NUTS WITH 5/16" HEX SOCKET OR END WRENCH ONTO LONG SCREWS AND TIGHTEN WITH 30 TO 50 INCH POUNDS TORQUE.
- POSITION SHELF ASSEMBLY IN DESIRED LOCATION AND MARK MOUNTING HOLE LOCATION ON BULKHEAD USING HOLES IN BRACKET, SHORT BRACE, AND LONG BRACE.
- ATTACH STRAP ASSEMBLY TO SHELVING BY INSERTING QUARTER TURN END FITTINGS INTO GROOVES ON PADDED SURFACE. ROTATE END FITTINGS ONE-QUARTER TURN CLOCKWISE TO LOCK IN PLACE. STRAP ASSEMBLY MAY BE SEPARATED BY REMOVING QUICK DISCONNECT HOOK FROM WIRE END OF FASTENER. DO NOT UNLACE WEBBING FROM FASTENER. FASTENER MAY BE CENTERED ALONG STRAP BY SLIDING WEBBING THROUGH THREADING PLATE.

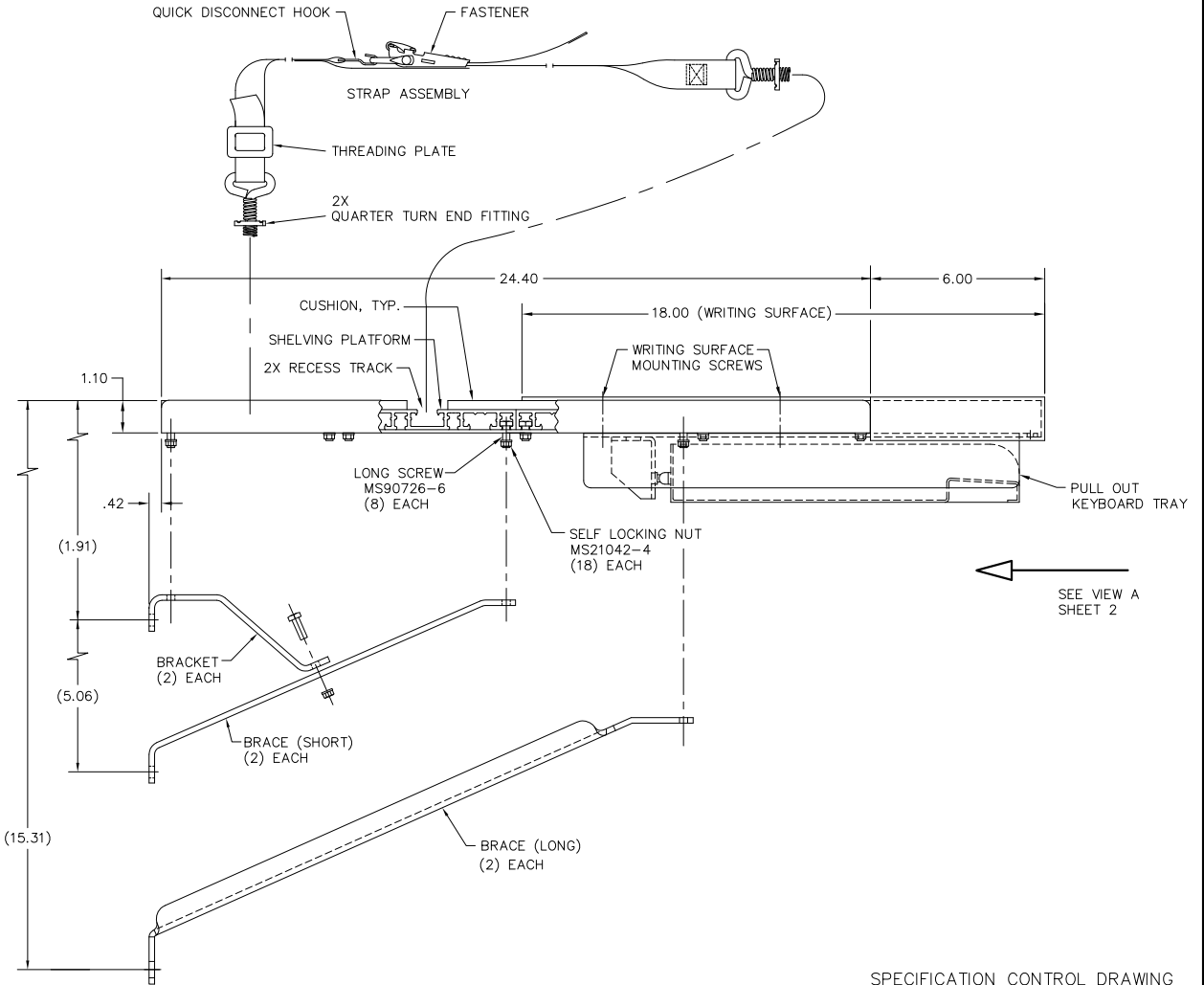

SEE VIEW A SHEET 2

SPECIFICATION CONTROL DRAWING

PART DASH NO.		QTY. REQ'D PER ASSY.	NEXT FINAL	NEXT ASSY.	USED ON	SIMILAR TO	ACT. WT. CALC. WT.	INTERPRET DIMENSIONS AND TOLERANCES IAW ASME Y14.5M-1994 UNLESS OTHERWISE SPECIFIED DIMENSIONS ARE IN INCHES DECIMALS .XX ±.015 ANGLES .5° XXX ±.010 DO NOT SCALE DRAWING FRESH	CONTRACTOR DRAWN L. HARTSIG DATE 7-8-00 CHECK P. LANE 1-13-05 APPROVED P. LANE 1-13-05 MANUFACTURING CUSTOMER	OGM CONTAINER CONTROLS, INC. P.O. BOX 40020 - TUCSON, ARIZONA 85717-0020 TITLE SHELVING, WITH WRITING SURFACE AND PULL OUT KEYBOARD TRAY SIZE FSCM NO. DDC NO. D 08992 KW24-3000(MOD) C SCALE 1/2 RELEASE DATE SHEET 1 OF 2
---------------	--	----------------------	------------	------------	---------	------------	--------------------	--	--	--

8 7 6 5 4 3 2 1

REVISIONS				
ZONE	LTR.	DESCRIPTION	DATE	APPROVED

D
C
B
A

D
C
B
A

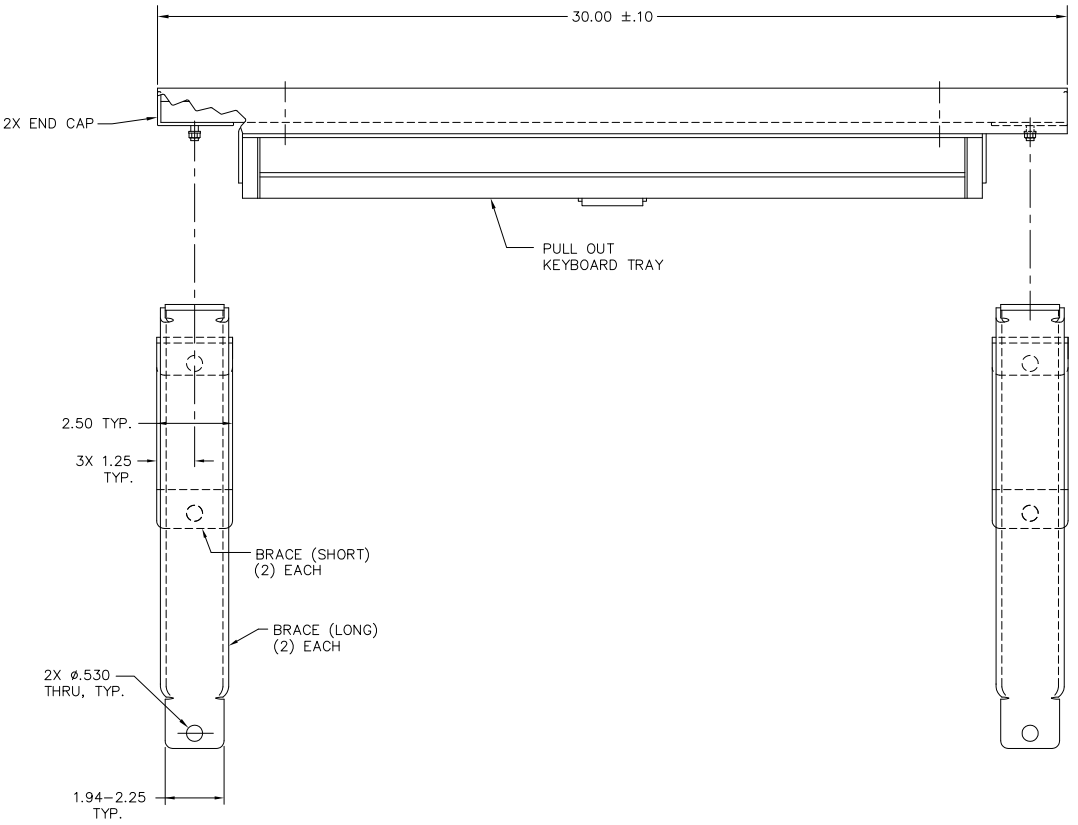

SIZE	FSCM NO.	DIR. NO.	REV
D	08992	KW24-3000(MOD)	C
SCALE	1/2	RELEASE DATE	SHEET 2