

THIS DOCUMENT CONTAINS PROPRIETARY INFORMATION AND EXCEPT WITH WRITTEN PERMISSION BY AGM CONTAINER CONTROLS, INC. SUCH INFORMATION SHALL NOT BE PUBLISHED, DISCLOSED TO OTHERS OR USED FOR ANY PURPOSE AND THE DOCUMENT SHALL NOT BE DUPLICATED IN WHOLE OR IN PART.

REVISIONS				
ZONE	LTR.	DESCRIPTION	DATE	APPROVED

NOTES:

1. DESCRIPTION: SHELVING KIT, WITH WRITING SURFACE, PULL OUT KEYBOARD TRAY, AND TIE DOWN STRAPS. SHELVING KIT IS SUPPLIED PARTIALLY ASSEMBLED AND REQUIRES ATTACHMENT OF BRACKETS AND BRACES AT TIME OF INSTALLATION. LOCATION OF BRACKETS AND BRACES ON UNDERSIDE OF SHELF MAY BE ADJUSTED SLIGHTLY TO LINE UP WITH MOUNTING REQUIREMENTS.
2. MATERIALS:
 - 2.1 SHELVING PLATFORM: 6061-T6 ALUMINUM EXTRUSION IAW QQ-A-200/8; 6.102 +.030 -.054 WIDE, (4) EACH.
 - 2.2 CUSHION: COMMERCIAL QUALITY, CLOSED CELL POLYVINYL CHLORIDE FOAM. UNCOMPRESSED THICKNESS APPROXIMATELY .38 INCH. CUSHION BONDED TO SHELVING PLATFORM WITH PERMANENT ACRYLIC PRESSURE SENSITIVE ADHESIVE.
 - 2.3 BRACKET, BRACE, END CAP, AND CLIP: 6061-T4 OR -T6 ALUMINUM ALLOY IAW QQ-A-200/8.
 - 2.4 WRITING SURFACE: POWDER COATED ALUMINUM, GUNMETAL GRAY.
 - 2.5 PULL OUT KEYBOARD TRAY: POWDER COATED STEEL, GUN METAL GRAY.
 - 2.6 STRAP ASSEMBLY: SEE DRAWING CT1109.

3. ASSEMBLY PROCEDURE:

- 3.1 ATTACH BRACKET TO SHORT BRACE USING LONG SCREW AND SELF LOCKING NUT, (2) PLACES. REMOVE LOOSE SELF LOCKING NUTS FROM LONG SCREWS ON BOTH END CAPS. PLACE BRACKET, SHORT BRACE AND LONG BRACE ON LONG SCREWS, AS SHOWN. INSTALL NUTS WITH 5/16" HEX SOCKET OR END WRENCH ONTO LONG SCREWS AND TIGHTEN WITH 30 TO 50 INCH POUNDS TORQUE.
- 3.2 POSITION SHELF ASSEMBLY IN DESIRED LOCATION AND MARK MOUNTING HOLE LOCATION ON BULKHEAD USING HOLES IN BRACKET, SHORT BRACE, AND LONG BRACE.
- 3.3 ATTACH STRAP ASSEMBLY TO SHELVING BY INSERTING QUARTER TURN END FITTINGS INTO GROOVES ON PADDED SURFACE. ROTATE END FITTINGS ONE-QUARTER TURN CLOCKWISE TO LOCK IN PLACE. STRAP ASSEMBLY MAY BE SEPARATED BY REMOVING QUICK DISCONNECT HOOK FROM WIRE END OF FASTENER. DO NOT UNLACE WEBBING FROM FASTENER. FASTENER MAY BE CENTERED ALONG STRAP BY SLIDING WEBBING THROUGH THREADING PLATE.

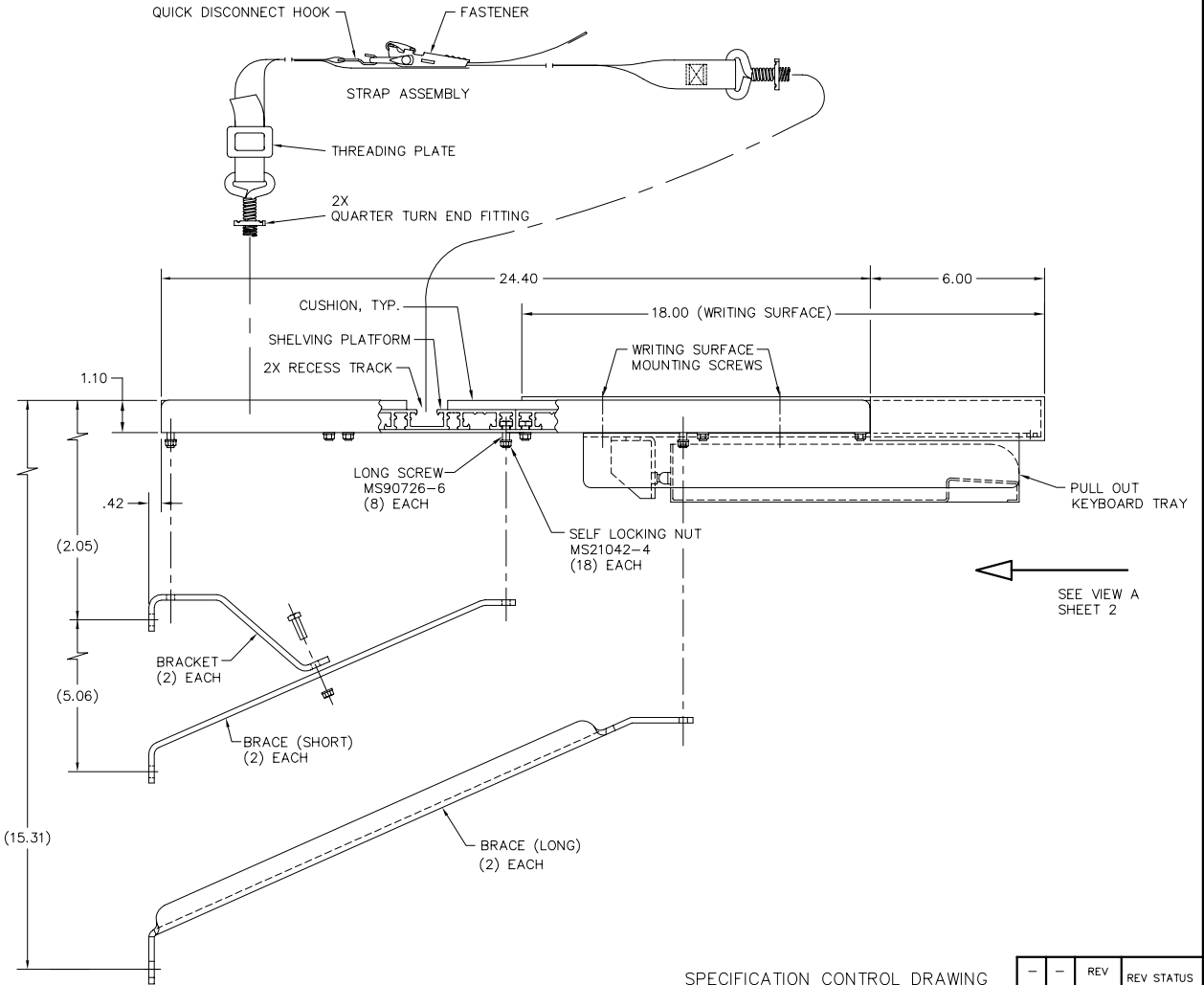

SPECIFICATION CONTROL DRAWING			REV	REV STATUS OF SHEETS
2	1	SHEET		

INTERPRET DIMENSIONS AND TOLERANCES IAW ASME Y14.5M-1994 UNLESS OTHERWISE SPECIFIED DIMENSIONS ARE IN INCHES DECIMALS: XX ±.015 XXX ±.010		CONTRACT	CGM CONTAINER CONTROLS, INC. P.O. BOX 40020 - TUCSON, ARIZONA 85717-0020	
DO NOT SCALE DRAWING		DRAWN	DATE	TITLE
FRESH		L. HARTSIG	7-8-00	SHELVING, WITH WRITING SURFACE AND PULL OUT KEYBOARD TRAY
PART DASH NO.		APPROVED	MANUFACTURING	SCALE 1/2
QTY. REQ'D PER ASSY.	NEXT ASSY.	USED ON	CUSTOMER	RELEASE DATE
APPLICATION	SIMILAR TO	ACT. WT. CALC. WT.		SHEET 1 OF 2
				FILE KW24-3000(MOD)

8 7 6 5 4 3 2 1

REVISIONS				
ZONE	LTR.	DESCRIPTION	DATE	APPROVED

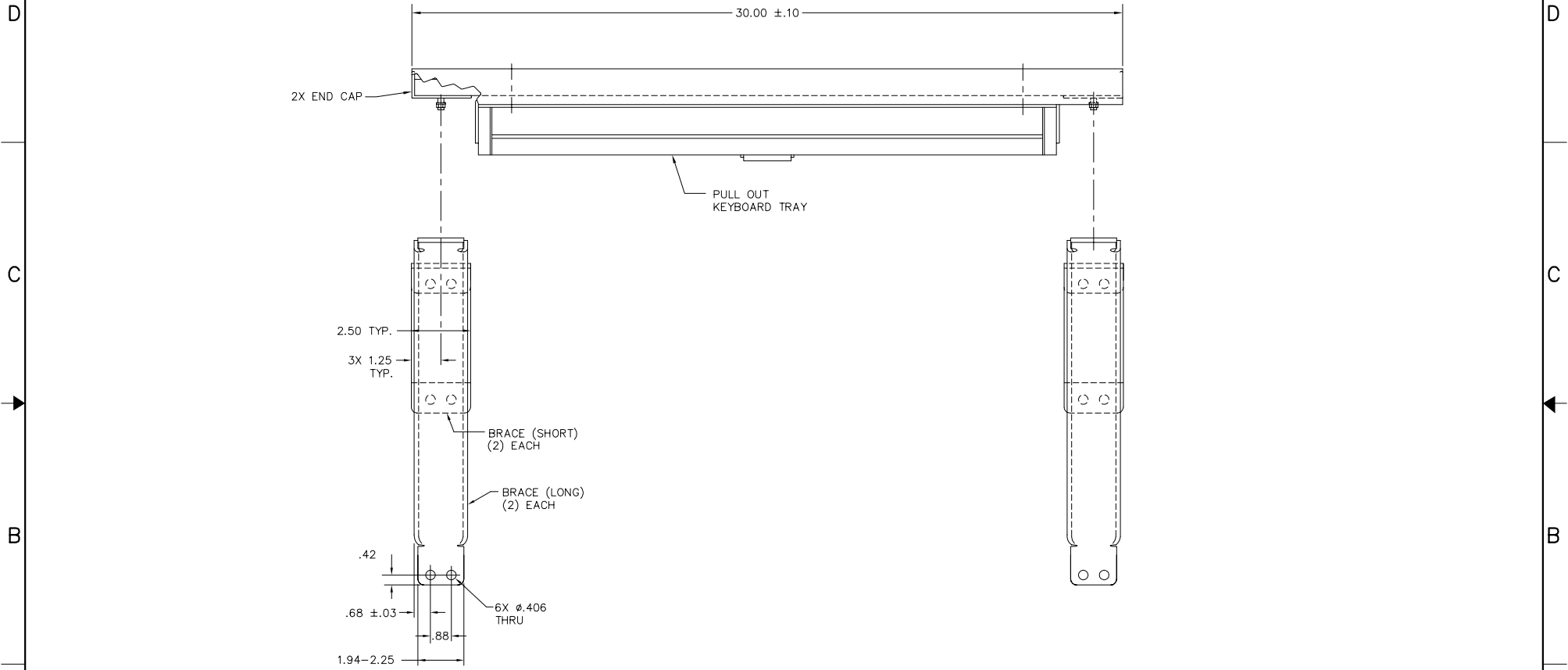

D
C
B
A

D
C
B
A

SEE SHEET 1 FOR REVISION STATUS

SIZE	FSCM NO.	DRWG. NO.	REV.
D	08992	KW24-3000	-
SCALE	RELEASE DATE	SHEET	
1/2		2	