



Records Holders



AGM CONTAINER CONTROLS, INC.
PO BOX 40020 • TUCSON ARIZONA 85717-0020
Tel: 800-995-5590 (520) 881-2130 • Fax: (520) 881-4983
www.agmcontainer.com • sales@agmcontainer.com



Sustaining Member



ISO 9001:2000
CERTIFIED

CATALOG 04R



Records Holders

AGM CONTAINER CONTROLS, INC.
 PO BOX 40020 • TUCSON ARIZONA 85717-0020
 Tel: 800-995-5590 (520) 881-2130 • Fax: (520) 881-4983
 www.agmcontainer.com • sales@agmcontainer.com

TA475

Adequate for a few sheets up to legal size (8 1/2" x 14").

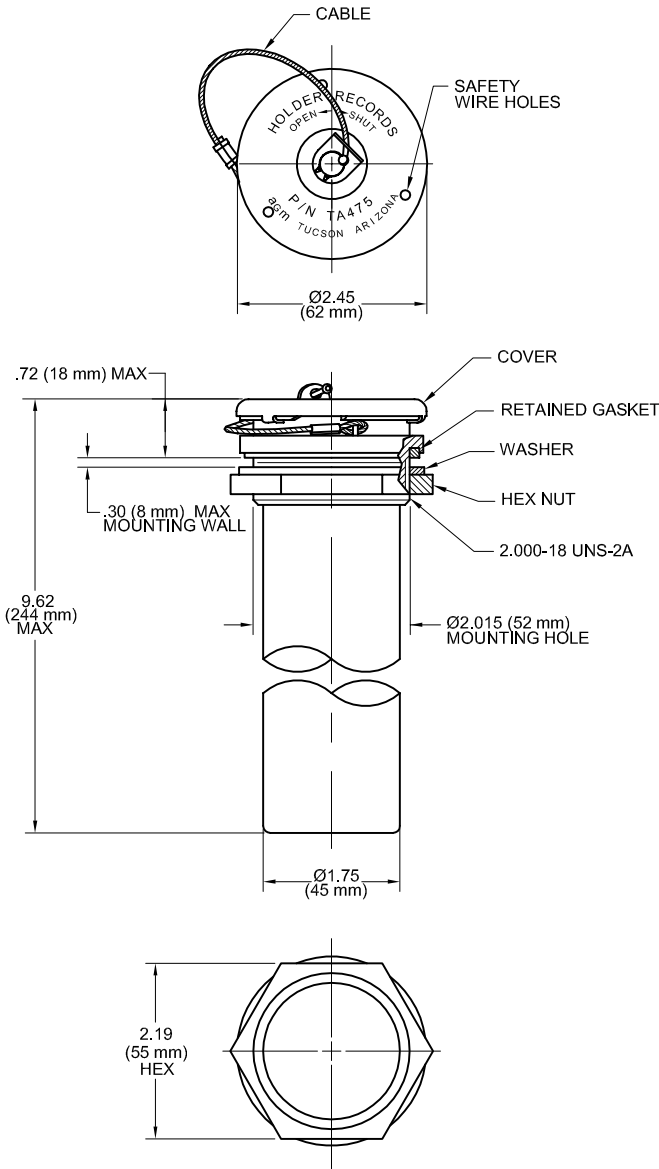

Min. inside dimensions:
 1.70 in. (43 mm) dia. x 9.0 in. (229 mm) long.

Weight: 0.31 lbs. (140 grams)

Materials & Finish

Aluminum alloys, conversion coated per MIL-C-5541. Stainless steel cover, passivated. Buna-N o-ring and gasket.

Torque value for hex nut: 80 in.-lbs. (9 N•m)

For use in shipping and storage containers, the TA475 Records Holder provides a convenient, safe and easily accessible place for inspection records and instructions.

The lightweight records holder is waterproof and is sealed from the inside of the container by a retained gasket. An o-ring in the spring loaded cover seals the records compartment from the outside.

Designed for mounting on a smooth, flat surface; it may not seal tightly if surface is curved or domed.

Simple to Use: Roll the records or instructions and insert into tube. Press on cover and twist about 30 degrees.

Easily Installed. Install holder through a 2.02" (51 mm) dia. hole in container wall. Gasket, washer and hex nut are furnished.

Tamper-Proof. Holes through cover and flange of records holder are provided for safety wiring and inspector's seal.



Records Holders

AGM CONTAINER CONTROLS, INC.
 PO BOX 40020 • TUCSON ARIZONA 85717-0020
 Tel: 800-995-5590 (520) 881-2130 • Fax: (520) 881-4983
 www.agmcontainer.com • sales@agmcontainer.com

TA485

Handles larger, bulkier, soft-covered documents. Also tools or other support items.

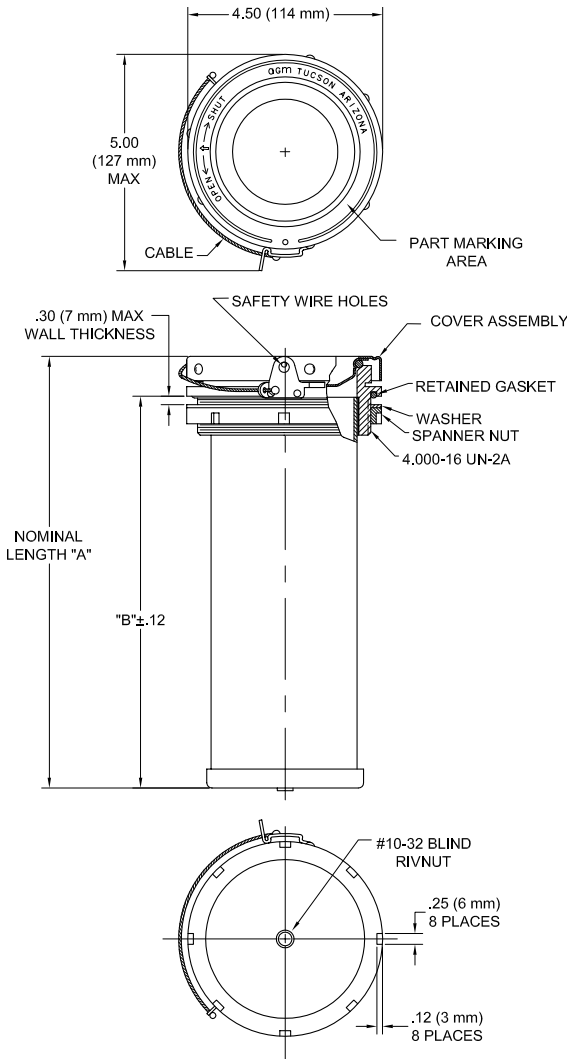

For use in larger shipping and storage containers, the TA485 Records Holder provides a convenient, safe and easily accessible place for inspection records, instructions or accessories. The records holder is waterproof and is sealed from the inside of the container. An o-ring in the spring loaded cover seals the records compartment from the outside.

Designed for mounting on a smooth, flat surface; it may not seal tightly if surface is curved or domed.

Simple to Use. Roll the records or instructions and insert into tube. Press on cover and turn about 60 degrees.

Easily installed. Install holder through a 4.015" (102 mm) dia. hole in container wall. Gasket, washer and spanner nut are furnished. Blind threaded insert provided in end of tube for additional support.

Tamper-Proof. Holes through cover and flange of records holder are provided for safety wiring and inspector's seal.

Part No.	A	B	C*	Weight
TA485-12	12.75 in. (324 mm)	11.75 in. (298 mm)	12 in. (305 mm)	1.85 lbs. (640 grams)
TA485-14	14.75 in. (375 mm)	13.75 in. (349 mm)	14 in. (356 mm)	2.00 lbs. (908 grams)

* Minimum inside dimension x 3.37 in. (86 mm) dia.

Materials & Finish

Aluminum alloys, conversion coated per MIL-C-5541. Stainless steel cover, passivated. Buna-N o-ring and gasket.

Torque value for spanner nut: 150 in.-lbs. (17 N•m).

QUALITY PRODUCTS FROM

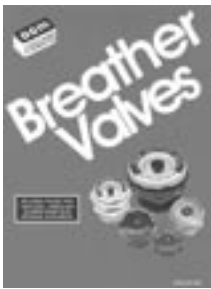

Catalog "B"



Catalog "IP"



Catalog "D"



Catalog "T"

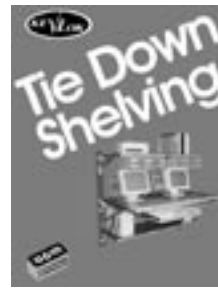

Catalog "K"



Catalog "SD"

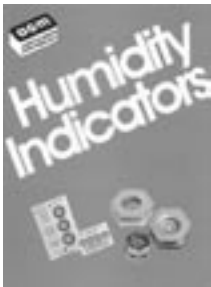

Catalog "H"

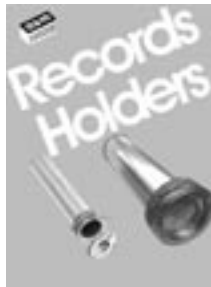

Catalog "R"



Catalog "P"



Catalog "DV"



Catalog "S"



Catalog "SW"

AGM CONTAINER CONTROLS, INC., backed by four decades of leadership in the manufacture of container hardware, has developed many products for military, electronic and industrial packaging, handling, storage and transportation applications. Individual catalogs (illustrated above) describing these products are available upon request. You are also cordially invited to phone, fax or e-mail for specific information regarding custom design, or to request assistance on your current and future requirements.

BREATHER VALVES Prevent excessive pressure or vacuum buildup in sealed containers, reducing weight, cube and cost. Meet SAE AS27166. Related item: Manual Relief Valves.

IMMERSION PROOF BREATHERS Permit air pressure equalization, but keep out liquid water. For use on membrane keyboards and similar pressure sensitive equipment that must operate under rain or water submersion conditions.

DESICCATORS Standard and custom-designed static drying units to fit a wide variety of applications. Valves and/or humidity indicators can be incorporated.

TIE DOWNS Patented over-center action of KevLok® fastener locks in tension. Adjustable. Holds tight, with quick release. Assemblies for military, industrial and recreational purposes. Also available: ratchet and cam buckle assemblies.

TIE DOWN SHELIVING For transport of delicate instruments in vans, trailers, etc. Meets Navy MIL-S-901D shock test for shipboard use. Padded aluminum shelving has recessed channels which accept adjustable KevLok® straps with quick attach/release end fittings.

SHELTER STATIC DEHUMIDIFIERS (SSD) Protect COTS equipment in mobile shelters for up to two years on a single bulk desiccant charge. Can be recharged from outside shelter.

HUMIDITY INDICATORS Provide external monitoring of humidity levels inside containers. Meet SAE AS26860. Related items: Propellant Leak Detectors and Observation Windows.

RECORDS HOLDERS Provide access to documentation or accessories without opening container. Records Holders compartment is sealed from the inside of the container.

DESICCANT AGM is a stocking distributor of Süd-Chemie Performance Packaging's Desi Pak® (which exceeds MIL-D-3464E requirements maintained within MIL-STD-2073-1C), Sorb-It®, Tri-Sorb®, Desi View® and Container Dri® products. Custom packaging of bulk desiccant available.

DRUMVENT DRYERS Prevent contamination of chemical products (powders, liquids and semi-solids) in 55-gallon storage drums. Reusable – saturated color change silica gel desiccant is easily replaced.

SHOCKMASTER® Shock overload indicators provide low-cost detection of transport and handling damage. Compact, accurate and reusable. "Red-flags" shipments which have been subjected to excessive shock or vibration.

SHOCKWATCH Single-use impact-detection device guards against careless handling. Self-adhesive label incorporates a tiny liquid filled tube that turns red when package is dropped.

Employee
Owned



AGM CONTAINER CONTROLS, INC.
3526 E FT LOWELL RD • PO BOX 40020 • TUCSON AZ 85717-0020
TEL: 800-995-5590 (520) 881-2130 • FAX: (520) 881-4983
www.agmcontainer.com • sales@agmcontainer.com



ISO 9001:2000
CERTIFIED

Form 7.2.29